

PSEN op2H-A series

Safety light curtain



pilz

This document is a translation of the original document.

All rights to this documentation are reserved by Pilz GmbH & Co. KG. Copies may be made for internal purposes. Suggestions and comments for improving this documentation will be gratefully received.

Pilz®, PIT®, PMI®, PNOZ®, Primo®, PSEN®, PSS®, PVIS®, SafetyBUS p®, SafetyEYE®, SafetyNET p®, the spirit of safety® are registered and protected trademarks of Pilz GmbH & Co. KG in some countries.



SD means Secure Digital

1	GENERAL INFORMATION	5
1.1	General description.....	5
1.1.1	General description of the safety light curtain.....	5
1.1.2	Package content	6
1.2	Guidelines for selecting the protective device	7
1.2.1	Resolution.....	7
1.2.2	Height of protected field	8
1.2.3	Minimum safety distance	9
1.3	Typical application areas	12
1.4	Safety information.....	13
2	INSTALLATION	14
2.1	Precautions to be taken during selection and installation of a light curtain	14
2.2	General information on positioning the device.....	15
2.2.1	Minimum distance from reflective surfaces	16
2.2.2	Distances between identical light curtains.....	17
2.2.3	Aligning transmitter and receiver.....	20
2.2.4	Using deviating mirrors	20
2.2.5	Inspections following a first-time installation.....	21
3	MECHANICAL ASSEMBLY	23
4	ELECTRICAL CONNECTIONS.....	25
4.1	Connection guidelines.....	27
5	ALIGNMENT	30
6	SETTING THE FUNCTIONS	32
6.1	Reset to factory configuration	33
6.2	Function list	33
7	FUNCTIONS.....	35
7.1	Restart function.....	35
7.2	Test	37
7.3	Reset	38
7.4	EDM	38
7.5	EDM selection.....	39
7.6	Reduced range	40
7.7	Muting.....	40
7.7.1	Disabling the muting function	41
7.7.2	Muting display devices.....	41
7.7.3	Typical muting application and sensor connection	42
7.7.4	Muting direction	42
7.7.5	Muting timeout	46
7.7.6	Partial muting.....	47
7.8	Override.....	47
7.8.1	Override mode.....	48
8	DIAGNOSTICS.....	50
8.1	Status of LEDs.....	50
9	REGULAR CHECKS AND MAINTENANCE	53
9.1	Regular checks	53
9.2	Maintenance	53

10 TECHNICAL DETAILS.....54
11 LIST OF AVAILABLE MODELS55
12 DIMENSIONS.....56
13 FITTINGS57
14 ACCESSORIES59
14.1 Rotating Mounting Bracket.....59
14.2 Connection cable60
14.3 Axial connection cable, unshielded61

1 GENERAL INFORMATION

1.1 General description

1.1.1 General description of the safety light curtain

The safety light curtains in the PSEN op2H-A series are multibeam active optoelectronic protective devices for work areas in which machines, robots and automated plants in general could endanger the physical integrity of operators who could come into contact with moving parts, even if only by chance.

Light curtains in the PSEN op2H-A series are designed as inherently safe Type 2 systems for accident prevention in accordance with applicable international safety standards, in particular the following:

IEC 61496-1: 2004 Safety of machinery: Electrosensitive protective equipment. Part 1: General requirements and tests.

IEC 61496-2: 2006 Safety of machinery: Electrosensitive protective equipment – Particular requirements for equipment using active optoelectronic protective devices.


A light curtain pair consists of a transmitter and a receiver. They produce an infrared protected field, which is able to detect an opaque object within the specific resolution. Both the transmitter and the receiver have control and monitoring functions. The connections are made via an M12 connector, which is located in the lower profile area. The transmitter and receiver are synchronised optically, so the two units do not have to be connected directly to each other. The infrared beams that are transmitted and received are controlled and monitored via a microprocessor, which provides the user with information about the operating state of the light curtain via LED indicators (see Chapter 8).

A light curtain pair consists of 2 units, which may comprise one or more transmitter and receiver modules, depending on the respective model. The receiver is the main control unit for all functions. If an error occurs, it checks all the safety actions and decides on the measures that are to be implemented in terms of safety, as well as performing other general functions.

During the installation phase the user interface makes it easier to align the two units (see Chapter 5).

As soon as the beams emitted from the transmitter are interrupted by an object, a limb or the body of an operator, both output signal switching devices (OSSD) are opened immediately. This controls the stopping of the corresponding machine, which is connected to the OSSD.

Some parts or paragraphs of this manual, which are of particular importance to the user or installation engineer, are highlighted as follows:

	<p>The information contained in paragraphs marked by this symbol is particularly relevant to safety and is important for accident prevention.</p> <p>This information must be read with particular attention and must be strictly observed.</p>
---	---

This manual contains all the information you need to select and operate the protective devices.

Specialised knowledge of safety issues is required to integrate a safety light curtain correctly in a plant.

PILZ's technical customer service team is available to provide any information you need regarding the functionality of the PSEN op2H-A safety light curtains and the safety regulations concerning correct installation.

1.1.2 Package content

The following components are included:

- Receiver (RX)
- Transmitter (TX)
- Shortform for installing the safety light curtains in the PSEN op2H-A series
- CD with operating manual and other documents
- 4 fastening brackets and corresponding mounting accessories
- 2 fastening brackets for models with a height between 1200 and 1800 mm

1.2 Guidelines for selecting the protective device

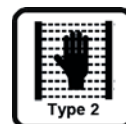
Once the hazards have been assessed appropriately, there are at least three essential features to consider when selecting a safety light curtain:

1.2.1 Resolution

The device's resolution is understood to be the minimum size that an opaque object must be to safely interrupt at least one of the beams that form the area of the protected field. The resolution is closely linked to the part of the body that requires protection.

R = 30 mm

Hand protection



As shown in Fig. 1, the resolution depends solely on the geometric properties of the lenses, the diameter and the distance and so is unaffected by the light curtain's ambient and operating conditions.

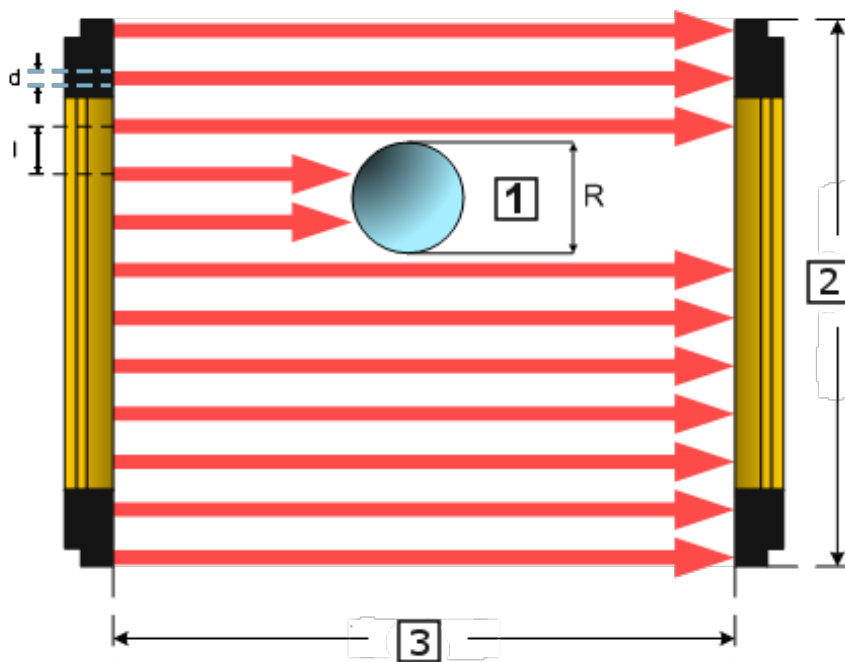


Fig. 1– Resolution

1	=	Opaque object
2	=	Height of protected field
3	=	Operating range

The resolution value can be calculated using the following formula:

$$R = l + d$$

where:

- l = Distance between two adjacent lenses
- d = Lens diameter

1.2.2 Height of protected field

The height of the protected field is understood to be the height protected by the safety light curtain.

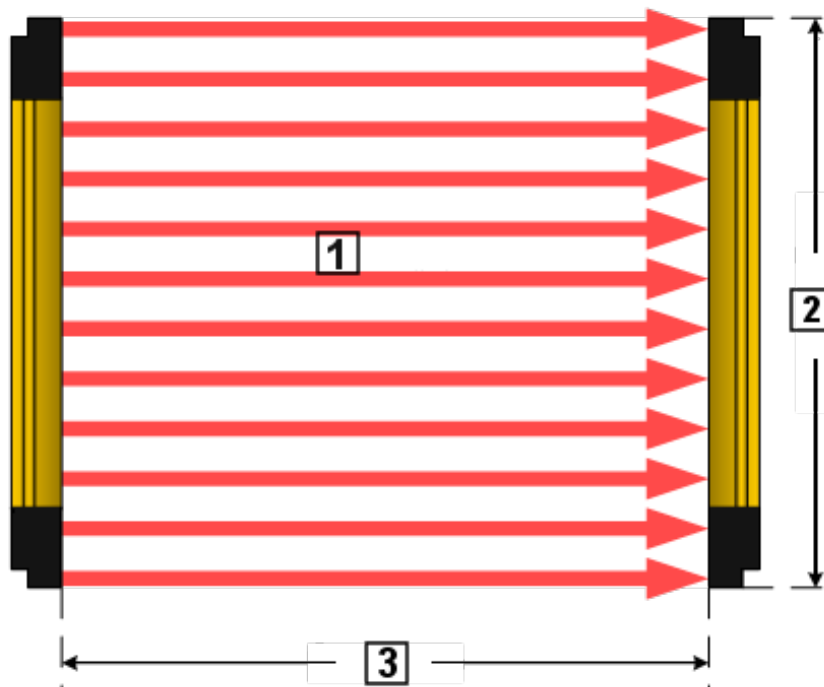


Fig. 2 – Height of protected field

1	=	Protected field
2	=	Height of protected field
3	=	Operating range

The height monitored by the PSEN op2H-A corresponds to the overall height of the light curtain.

With reference to the previous diagram, the height of the protected field can be taken from the table below.

Model	Height of protected field (mm)
PSEN op2H-A-30-030/1	300
PSEN op2H-A-30-045/1	450
PSEN op2H-A-30-060/1	600
PSEN op2H-A-30-075/1	750
PSEN op2H-A-30-090/1	900
PSEN op2H-A-30-105/1	1050
PSEN op2H-A-30-120/1	1200
PSEN op2H-A-30-135/1	1350
PSEN op2H-A-30-150/1	1500

PSEN op2H-A-30-165/1	1650
PSEN op2H-A-30-180/1	1800

1.2.3 Minimum safety distance

The protective device must be positioned at a specific safety distance (Fig. 3), which guarantees that the operator cannot reach the danger zone until the hazardous machine movement has come to a standstill by triggering the light curtain.

In accordance with the standard ISO 13855, this distance depends on 4 factors:

- Response time of the light curtain (the time that elapses between the beams being effectively interrupted and the OSSD contacts opening).
- Machine's stopping performance (time that elapses between the light curtain contacts opening and the hazardous machine movement effectively stopping).
- Light curtain's resolution
- Approach speed of the object to be detected.

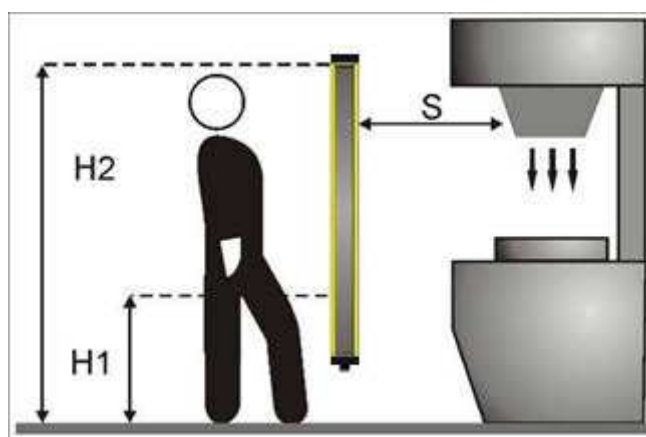


Fig. 3 – Safety distance (vertical)

H1	=	≥ 900 mm at a resolution > 40 mm
H2	=	≤ 300 mm at a resolution > 40 mm
S	=	Minimum safety distance in mm

The safety distance is calculated using the following formula:

$$S = K (t1 + t2) + C$$

Therefore:

S	Minimum safety distance in mm
K	Speed of the object (limb or body) approaching the danger zone in mm/s
t1	Light curtain's response time in seconds (see Chapter 11)
t2	Machine's stopping performance in seconds
C	Additional distance based on the possibility of placing the body or limb into the danger zone before the protective device responds
	C 8 (d -14) for devices with a resolution ≤ 40 mm
	C 850 mm for devices with a resolution > 40 mm
d	Device's resolution

Note:

The value K corresponds to:

- 2000 mm/s, if the calculated value S is ≤ 500 mm
- 1600 mm/s, if the calculated value S is > 500 mm

When using light curtains with a resolution of > 40 mm, the upper beam must be positioned at a height of ≥ 900 mm (H2) from the supporting base, while the lower beam must be positioned at a height of ≤ 300 mm (H1).

Where the light curtain must be installed horizontally (Fig. 4), the distance between the danger zone and the most distant optical beam must correspond to the value calculated using the following formula:

$$S = 1600 \text{ mm/s} (t1 + t2) + 1200 - 0.4 H$$

Therefore:

S	Minimum safety distance in mm
t1	Light curtain's response time in seconds (see Chapter 11)
t2	Machine's stopping performance in seconds
H	Height of the beams above the floor. This height must always be less than 1000 mm.

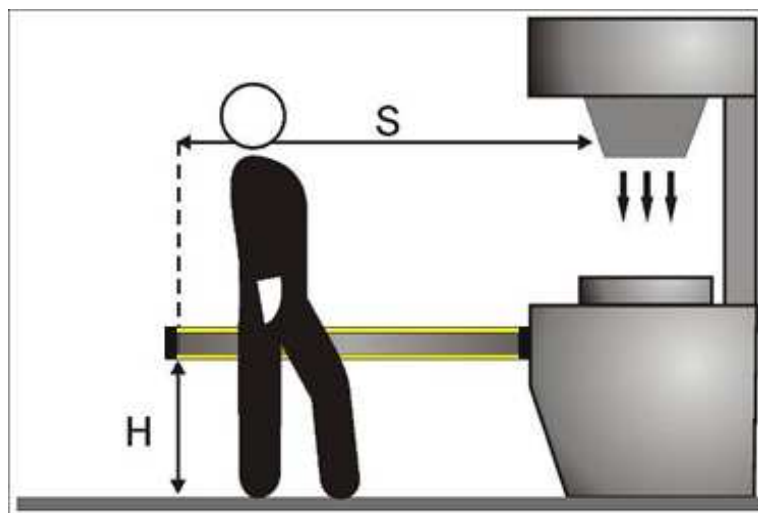


Fig. 4 – Safety distance (horizontal)

Application examples

This example is based on a light curtain with a height = 600 mm.

To calculate the distance of the device from the light curtain in a vertical position, the following formula is applied:

$$S = K \cdot T + C$$

Therefore:

$$T = t_1 + t_2$$

t_1 = Response time of light curtain + release time of relay (specific time of PNOZ S3: 20ms)

With a reaction time of the light curtain of 15 ms the result is a max. of 35 ms for t_1

t_2 = Machine's overall stopping performance in seconds

$C = 8 \cdot (d - 14)$ for devices with resolution ≤ 40 mm

D = Resolution

In each case, if $K = 2000$ mm/sec, then $S > 500$ mm. The safety distance will then need to be recalculated, based on $K = 1600$ mm/sec.



WARNING: In this case the reference standard is EN ISO 13855 "Safety of machinery – Positioning of protective equipment in respect of approach speeds of parts of the human body". The information provided here should be regarded as a summary and is non-binding. Please refer to the complete standard ISO 13855 for details of how to calculate safety distances correctly.

1.3 Typical application areas

Example 1: Protecting the operating area on drilling machines



The operator inserts the workpiece and removes it after machining. The operator must be protected from injury during the machining process.

Solution: The safety light curtain PSEN op2H-A is particularly suitable for this application, as the device needs to be installed directly on the machine.

Benefits: The small dimensions of the light curtain guarantee maximum flexibility during installation, as it can be adapted to the machine dimensions.

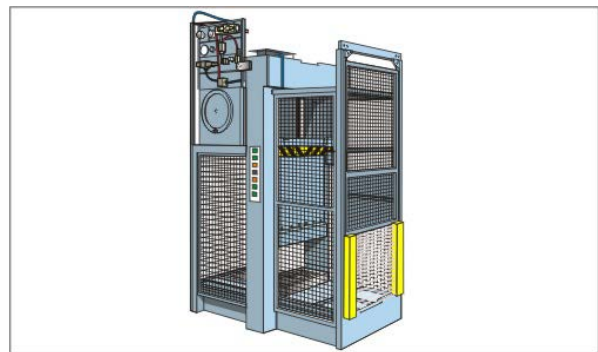
Rotatable mounting brackets are included, guaranteeing fast, simple attachment.

Example 2: Bending presses

The safety device must protect the bending process operator from the crushing hazard that exists between the upper and lower tool or from the workpiece that is being machined, if this approaches at high speed.

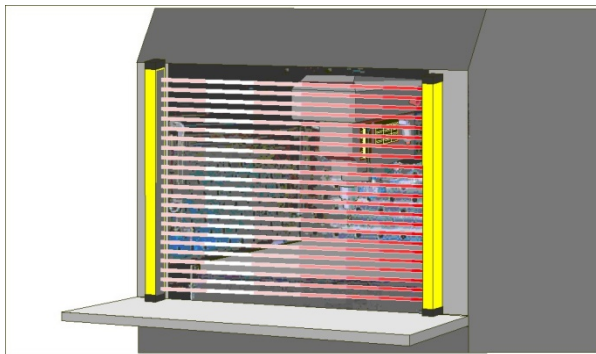
Solution: Even if just one light axis on the safety light curtain PSEN op2H-A is interrupted during the downward phase, the movable workpiece carrier is stopped immediately.

Benefits: The simple installation options and the small dimensions of the safety light curtain mean it can be used in most bending operations. PSEN op2H-A not only guarantees a high level of reliability but also increases production on the plant, as the standstill times needed for access, settings and machine maintenance can be reduced.



Example 3: Paper cutting machine

A typical application for these protective devices is on paper cutting machinery for magazines and special formats. The purpose of the light curtain is to protect the operator from cuts or abrasions from the cutting machine.



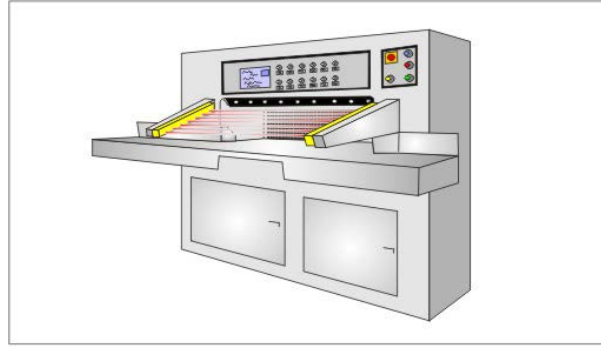
Solution: The safety light curtain PSEN op2H-A is particularly suitable for this application, as the device needs to be installed directly on the machine.

Benefits: The small dimensions of the light curtain and the guide rails at either end guarantee maximum flexibility, as they can be adapted to the machine's mechanical

dimensions.

Example 4: Moulding machine

The moulding machine is used to create complex shapes from metallic parts or parts made from other materials. In this case it is necessary to prevent the operator's hands or other limbs being dragged, entangled or cut by the tool itself or being injured by the spindle.



Solution: The safety light curtain from the PSEN op2H-A series is the best solution for protecting the operator in terms of the required safety level and the application type. As soon as even a single beam on the light curtain is interrupted, the machine is stopped immediately.

Benefits: The small dimensions of the light curtain with no dead zones guarantees maximum flexibility during installation, as it can be adapted to the machine dimensions.

1.4 Safety information


	To use the safety light curtains in the PSEN op2H-A series safely and correctly, the following information must be considered:
--	---

- The system intended to stop the machine must be electrically controllable.
- This control system must be able to stop hazardous machine movements
 - inside the overall stopping performance of the machine T,
 - in accordance with the details in Chapter 1.2.3 of the operating manual (see CD provided)
 - and in each phase of the processing cycle.
- The protective device must be positioned at a distance that exceeds the minimum safety distance S or that corresponds to it, which guarantees that the operator cannot reach the danger zone until the hazardous machine movement of the object has come to a standstill by triggering the light curtain.
- The safety light curtains may only be installed and connected by qualified personnel. It is essential to follow the instructions provided in the relevant sections of the manuals provided (see Chapters 2, 3, 4 and 5) and to comply with the applicable directives.
- Ensure that the correct operation of the light curtain is not disturbed by strong electromagnetic interference.
- Avoid installing the light curtain, particularly the receiver, close to particularly intense and/or flashing light sources.
- The safety light curtain must be positioned so that it safely prevents access to the danger zone without interrupting the beams (see Chapters 2, 3).
- Only qualified personnel with appropriate knowledge of all the operating procedures of the safety light curtain should be permitted to work within the danger zone.
- The RESET button must be positioned outside the area of the protected field and in such a way that the operator can see into the danger zone when carrying out a reset and test procedure.
- Reflective surfaces close to the beams emitted from the protective device (whether from above, below or from the side) can cause passive reflections that adversely affect the operation of the light curtain.


The instructions provided for correct operation must be strictly followed before switching on the light curtain.


2 INSTALLATION

2.1 Precautions to be taken during selection and installation of a light curtain

	Ensure that the safety level guaranteed by the PSEN op2H-A (Type 2) complies with the actual risk assessment of the machine to be monitored, as well as the level defined by the standard EN 13849.
---	---

	Ensure that the light curtain's outputs (OSSD) are used as machine stopping devices and not as control devices. The machine must have a separate START control.
---	---

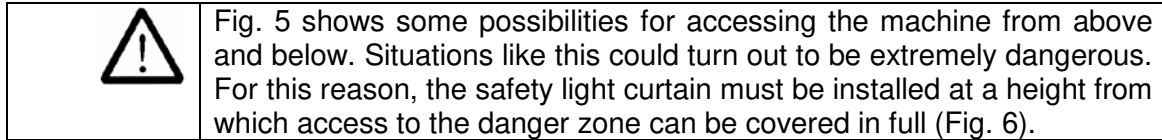
	Ensure that the correct operation of the light curtain is not disturbed by strong electromagnetic interference.
---	---

	Ensure that the light curtain, particularly the receiver, is not installed close to particularly intense and/or flashing light sources.
---	---

- The size of the smallest object to be detected must be greater than the device's resolution.
- The light curtain must be installed in an environment that complies with the technical properties stated in Chapter 11.
- Smoke, mist or dust in the working environment can reduce the operating range of the protective device.
- Sudden, large-scale temperature variations, particularly with low temperatures can generate a slight layer of condensation on the device's lens, adversely affecting its function.
- Reflective surfaces close to the beams emitted from the protective device (whether from above, below or from the side) can cause passive reflections that adversely affect the operation of the light curtain.
- The protective device must be positioned at a distance that exceeds the minimum safety distance S or that corresponds to it, which guarantees that the operator cannot reach the danger zone until the hazardous machine movement of the object has come to a standstill by triggering the light curtain.

2.2 General information on positioning the device

Special care should be taken when positioning the safety light curtain to ensure it provides efficient protection. The device must be installed so that the danger zone cannot be accessed without interrupting the protected field.



NO



Fig. 5 – Device positioned incorrectly



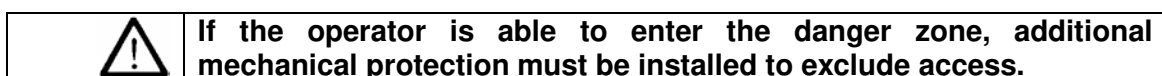
YES

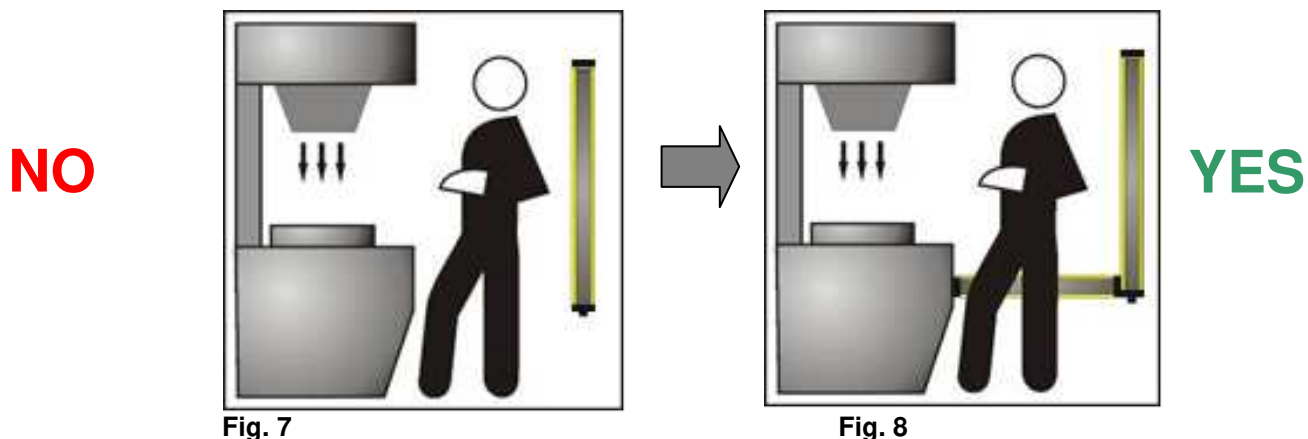


Fig. 6 – Device positioned correctly

Under normal operating conditions, the machine may only be started if the operator is outside the danger zone.

If it is impossible to install the light curtain in the immediate vicinity of the danger zone, the possibility of access from the side must be excluded, for example, by installing a second horizontal light curtain. See Fig. 8.





2.2.1 Minimum distance from reflective surfaces

Reflective surfaces close to the beams emitted from the protective device (whether from above, below or from the side) can cause passive reflections. These passive reflections can adversely affect how the object is detected within the protected area. If the receiver RX detects a secondary beam (reflected by the side-reflecting surface), the object may not be detected even if it interrupts the main beam.

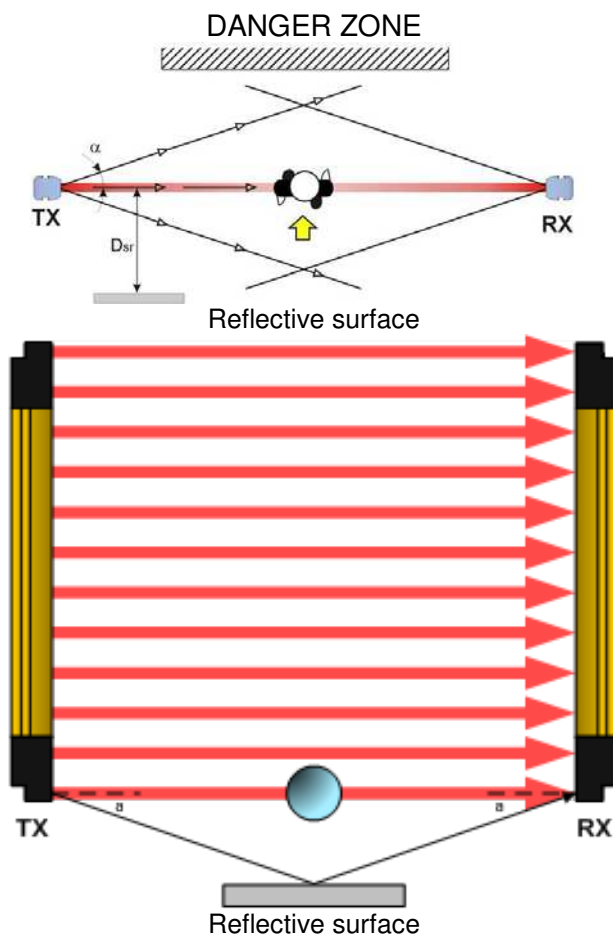


Fig. 9 Minimum distance from reflective surfaces

When installing the safety light curtain it is important to maintain a minimum distance from reflective surfaces.

This minimum distance depends on the following factors:

- The distance between the transmitter (TX) and receiver (RX)
- The actual opening angle of the light curtain; in particular:

when Type 2 light curtain = 10° ($\alpha = \pm 5^\circ$)

The illustration in Fig. 10 shows the minimum distance from the reflective surface (D_{sr}) based on the operating range:

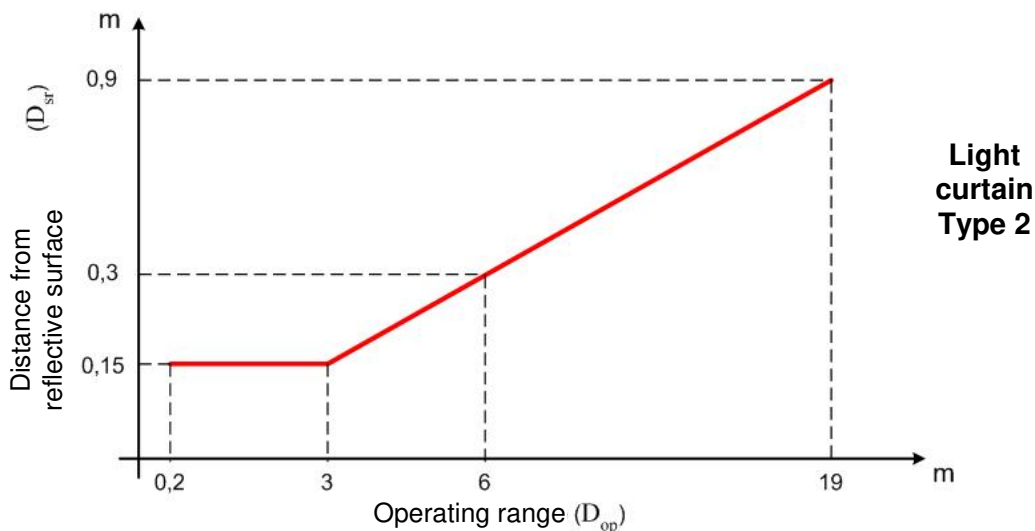


Fig. 10

Formula for calculating D_{sr} :

D_{sr} (m)	=	0.15	With operating ranges < than 3 m
D_{sr} (m)	=	$0.5 \times \text{operating range (m)} \times \text{tg } 2\alpha$	With operating ranges \geq than 3 m

2.2.2 Distances between identical light curtains

Should it be necessary to install several protective devices in adjacent areas, care must be taken to ensure that the transmitter on one of the pairs does not dangerously interfere with the receiver on another pair.

The interfering transmitter, TX B, must be installed outside the minimum distance D_{do} from the TX A - RX A axis of the transmitter/receiver pair.

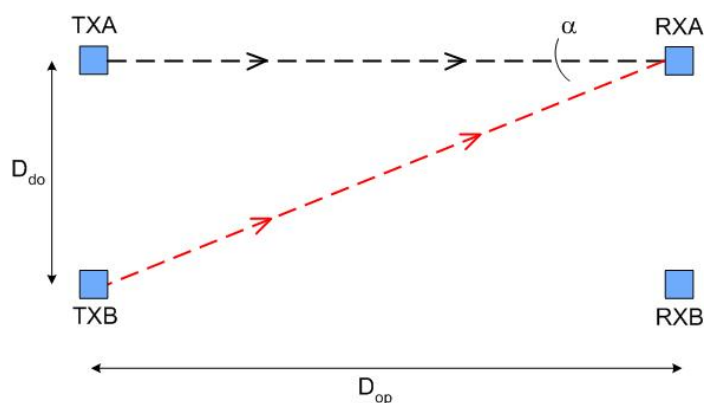


Fig. 11 – Distance between devices of the same type

This minimum distance D_{do} depends on the following factors:

- The distance between the transmitter (TX A) and receiver (RX A);
- The actual opening angle of the light curtain.

The following graphic shows the distance from the interfering devices (D_{do}), based on the operating range (D_{op}) of the pair (TX A – RX A).

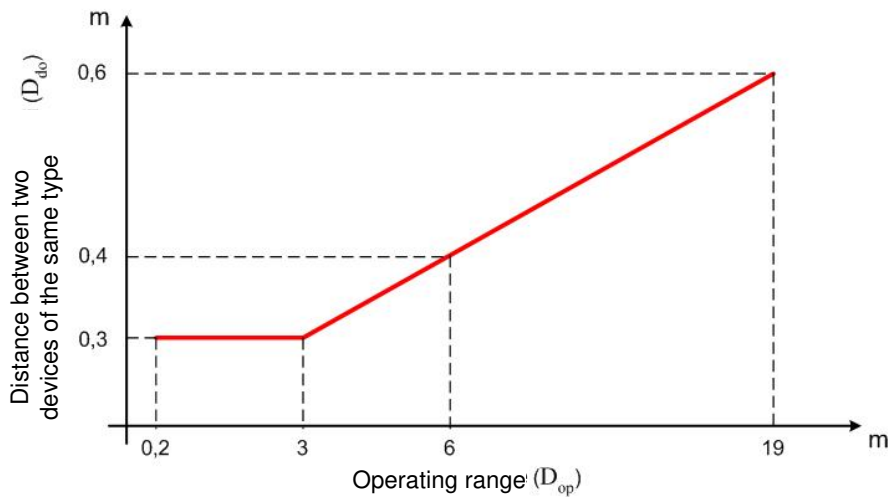


Fig. 12

For the purpose of simplification, the table below states the values of the minimum safety distances required for installation, with reference to some operating ranges.

Operating range (m)	Minimum safety distance (m)
3	0.3
6	0.4
10	0.5
19	0.6


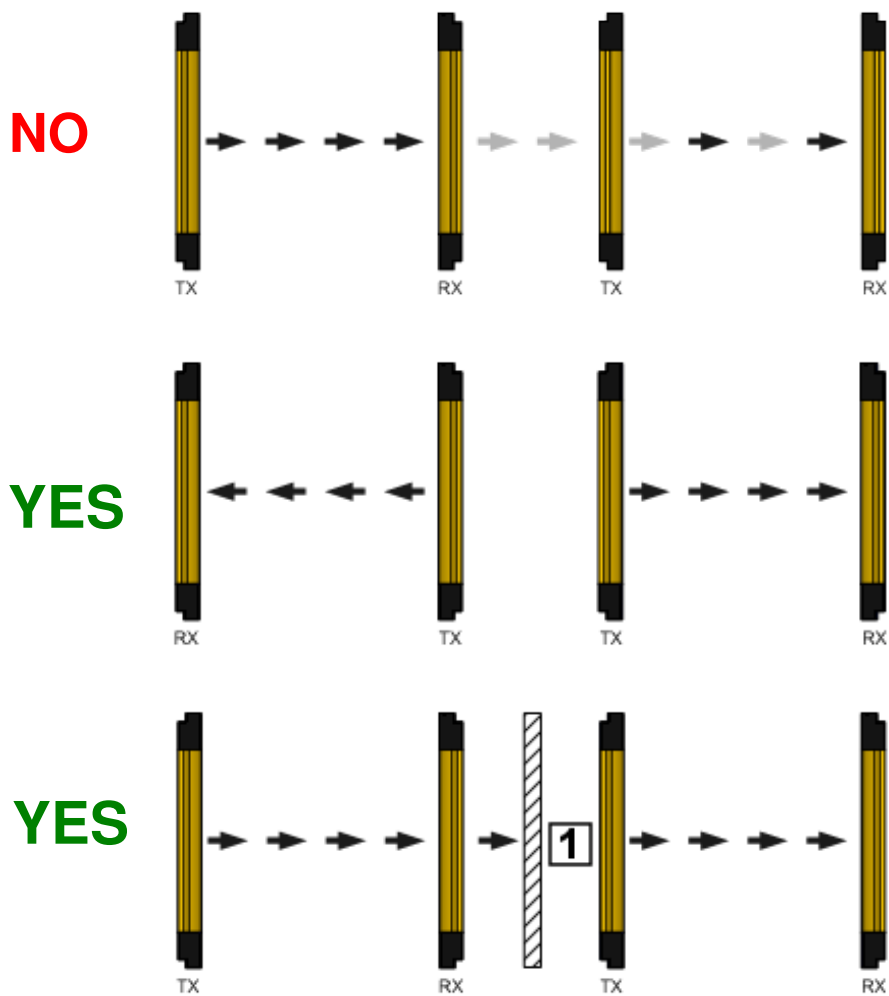
	<p>WARNING: The interfering transmitter (TX B) must be positioned at the same distance D_{do}, as calculated above, even if the distance from the other transmitter TX A is shorter than from the receiver RX A.</p>
---	--

Fig. 13 shows an example of an installation in which interference may occur, along with two potential remedies.



① Opaque partition

Fig. 13 – Interference between adjacent light curtains

2.2.3 Aligning transmitter and receiver

The light curtain pair must be arranged in parallel to each other. Transmitter and receiver have connections underneath. Both units must be installed at the same time.

Make sure that the light curtains are not configured as shown in Fig. 14.



Fig. 14 – Light curtain alignment

2.2.4 Using deviating mirrors

If a single safety device is used, danger zones with different but adjacent access sides can be monitored using well-positioned deviating mirrors.

Fig. 15 shows a possible solution, which can be used to protect three access sides using two mirrors. The deviating mirrors should be positioned at a 45° angle to the light axes.

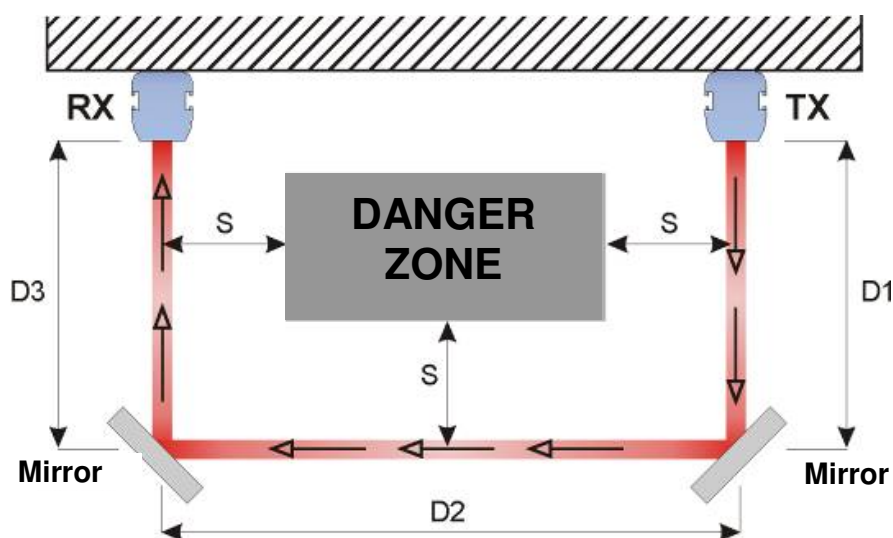


Fig. 15- Using deviating mirrors

When deviating mirrors are used, the following precautions must be taken and conditions considered:

- When deviating mirrors are used, the alignment of the transmitters and receivers requires higher precision. Perfect alignment can be lost even with only a minor angular displacement of the mirror. In this case we recommend you use the laser pointer, which is available as an accessory.
- The minimum safety distance (S) must be maintained for all sections of the beam.
- Use of a single deviating mirror reduces the effective operating range by about 15%. This percentage increases when two or more deviating mirrors are used (more detailed information is provided in the technical specifications for the relevant mirror).

The table below states the operating ranges based on the number of mirrors used.

Number of mirrors	Operating range (30 mm)
1	16.5 m
2	13.7 m
3	11.6 m

- Never use more than three mirrors per device.
- Any dust or dirt on the mirror's reflective surface will drastically reduce the operating range.

2.2.5 Inspections following a first-time installation

Listed below are the control measures that must be taken following a first-time installation, prior to starting the machine. Tests must be carried out by qualified personnel or directly by the person in charge of machinery safety / under his or her supervision.

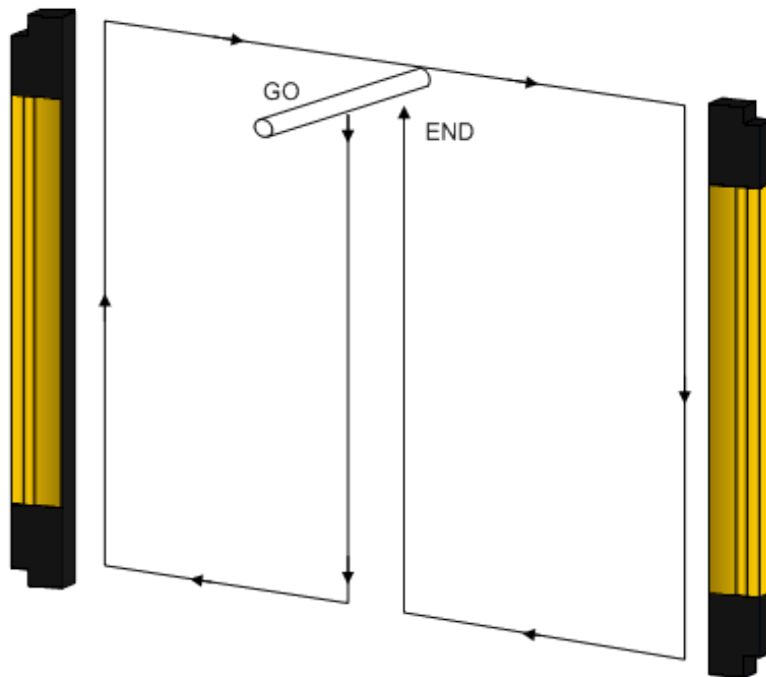


Fig. 16 – Path of test object

Perform the following checks:

- The light curtain is in a safe state (OSSDs off)
 - The beams are interrupted across the whole area of the protected field using a test object (test rod) (TP-30) with an appropriate resolution, in accordance with the diagram in Fig. 16.
- Is the light curtain aligned correctly?
 - Press gently on the side of the product in both directions. The red LED must not light during this process
- Activate the TEST function on the TX side.
 - The OSSD outputs are opened (red LED, OSSD on the RX side, ON and stop of the controlled machine).
- The response time to the status of the machine STOP, including the response time of the light curtain and machine, is within the limit values defined for calculating the safety distance (see Chapter 2.2).
- The safety distance between the danger zones and the light curtain complies with the details specified in Chapter 2.2.
- Access and exposure of persons between the light curtain and hazardous machine components is prevented.
- It is impossible to access the machine's danger zones from an unprotected side.
- In order to guarantee that the light curtain remains in NORMAL FUNCTION MODE for at least 10-15 minutes and, after positioning the specific test object in the protected field, stays in a SAFE STATE for the same time span, there must be no interference from external light sources.
- Check that all additional functions comply by activating them several times under different operating conditions.

3 MECHANICAL ASSEMBLY

The transmitter (TX) and receiver (RX) must be assembled with their sensing surfaces facing each other. The connectors must be positioned on the same side and the distance must be within the operating limits of the relevant model (see Chapter 11).

The pair of light curtains must be aligned to the best possible extent and must be as parallel as possible.

The devices will be precision aligned in accordance with the description in Chapter 5.

The fastening kit supplied can be used as follows (Fig. 17).

To assemble the kit with the mounting brackets, place the bolts into the dedicated side guide rail. Slide the insert along the groove of the metal profile. Attach the bracket by tightening the M5 hexagonal nuts on the profile. It is possible to slide the bracket unit along the dedicated rail and then reposition it by tightening the above-mentioned nuts.

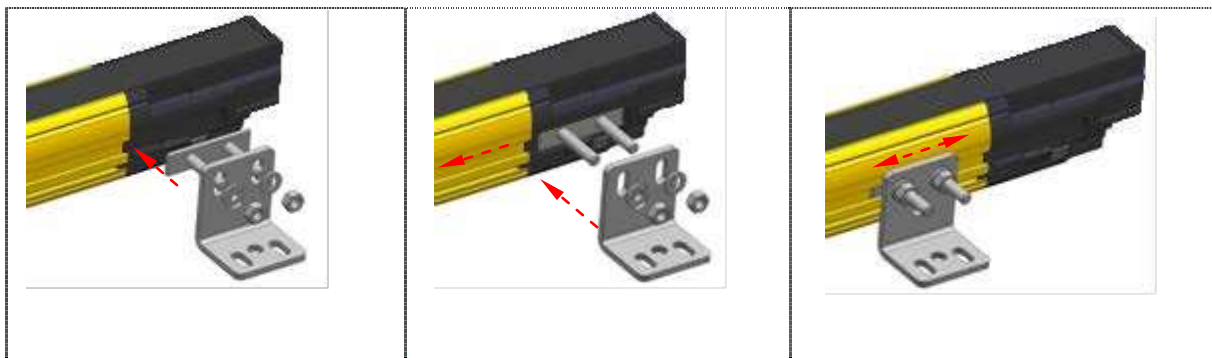


Fig. 17 – Procedure with fixed mounting brackets

On applications where there is particularly heavy vibration, we recommend that you use anti-vibration rubbers with the mounting brackets to alleviate the effects of the vibration.



Fig. 18 - Anti-vibration rubbers

The mounting positions recommended based on the length of the light curtain are stated in Fig. 19 and in the following table.

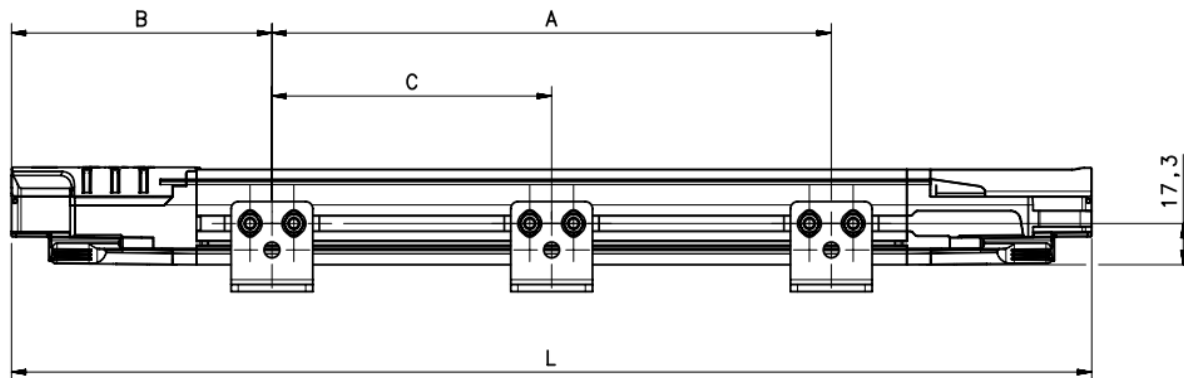


Fig. 19 – Light curtain dimensions

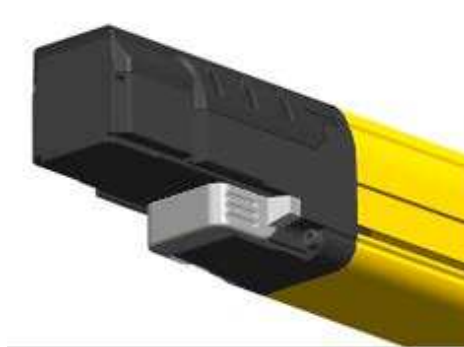
MODEL	L (mm)	A (mm)	B (mm)	C (mm)
PSEN op2H-A-30-030/1	306,3	86,3	110	-
PSEN op2H-A-30-045/1	456,3	236,3	110	-
PSEN op2H-A-30-060/1	606,2	306,2	150	-
PSEN op2H-A-30-075/1	756,2	406,2	175	-
PSEN op2H-A-30-090/1	906,1	506,1	200	-
PSEN op2H-A-30-105/1	1056,1	606,1	225	-
PSEN op2H-A-30-120/1	1206	966	150	453
PSEN op2H-A-30-135/1	1356	1066	175	503
PSEN op2H-A-30-150/1	1505,9	1166	200	553
PSEN op2H-A-30-165/1	1655,9	1266	225	603
PSEN op2H-A-30-180/1	1805,8	1366	250	652,9

4 ELECTRICAL CONNECTIONS

18-pin rectangular pigtail cables are used at the light curtain for electrical connections. The pigtail cable has M12 connectors with a different number of pins on the opposite side.

On muting models, the receiver is equipped with one 12-pin M12 connector and one 5-pin M12 connector.

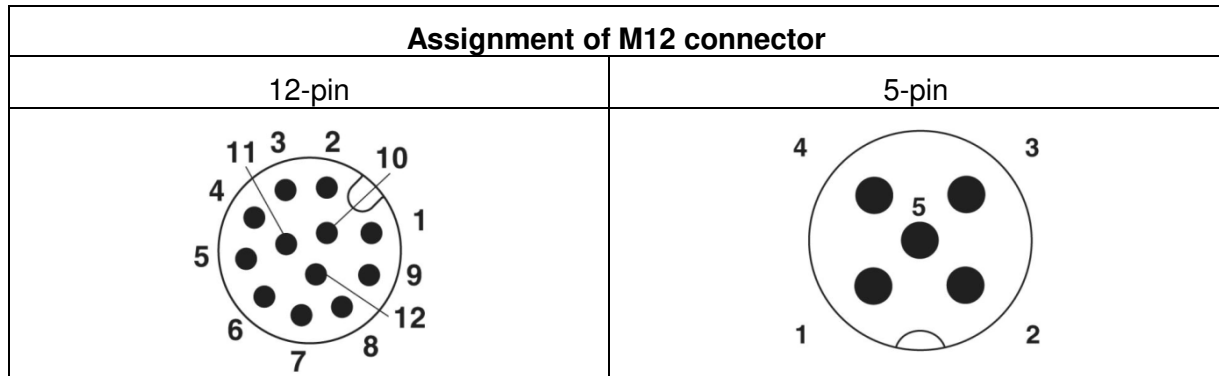
After removing the cap shown in grey (see Fig.) the cables must be connected at the bottom of the light curtain (the end with LEDs and buttons).

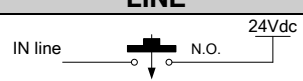
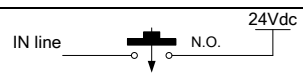
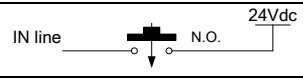
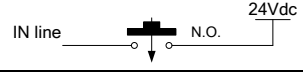
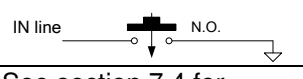
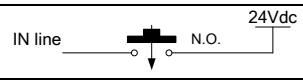
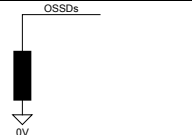
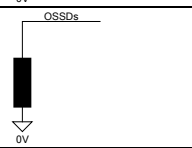
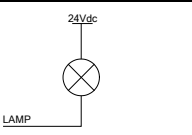
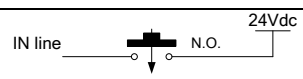


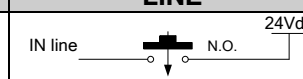
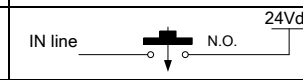
Make sure that the terminator cap (see Chapter 13) is connected on the top of the light curtain. If this connection is missing, the Master and Slave units will switch to a critical communication state.

PSENopt Advanced RX Muting	
	<p>M12 12-Pin:</p> <ol style="list-style-type: none"> 1. 24 V (brown) 2. 0 V (blue) 3. RESET/RESTART/ALIGN (white) 4. OVERRIDE1 (green) 5. OSSD2 (pink) 6. EDM (yellow) 7. MUTING DEACTIVATION (black) 8. OSSD1 (grey) 9. OVERRIDE2 (red) 10. MUTING LAMP (purple) 11. OVERRIDE STATUS (grey-pink) 12. EARTHING (red-blue) <p>M12 5-Pin:</p> <ol style="list-style-type: none"> 1. 24 V (brown) 2. MUTING2 (white) 3. 0 V (blue) 4. MUTING1 (black) 5. NC (grey)

PSENopt Advanced TX	
	<p>M12 5-Pin:</p> <ol style="list-style-type: none"> 1. 24 V (brown) 2. TEST (white) 3. 0 V (blue) 4. EARTH (black) 5. REDUCED RANGE (grey)




PSENopt Advanced RX Muting		
CONNECTION	LINE	BEHAVIOUR
RESET		Is connected – when in disabled state the RESET/RESTART/ALIGN button is operated
RESTART		Is connected – when during operation the RESET/RESTART/ALIGN button is operated
ALIGNMENT		Has to be set to 24 V DC at startup
OVERRIDE 1		Is connected – when Override is active during operation
OVERRIDE 2		No voltage – during operation
EDM	See section 7.4 for connections	Must be non-equivalent to OSSD during operation with EDM enabled
MUTING DEACTIVATION		Muting is disabled when connecting
OSSD1 / OSSD 2		Protected field clear No voltage = Protected field not clear
OVERRIDE STATUS		High level = Override function active Low level = Override function inactive NOTE: This line signals the state of the override signal inputs
MUTING LAMP		The open collector connection is activated when muting is activated.
MUTING1/MUTING2		Is connected – when muting is active during operation
FUNCTION EARTH		Connect to earth

PSENopt Advanced TX		
CONNECTION	LINE	BEHAVIOUR
TEST		Is connected – when the RESET button is operated during operation
REDUCED RANGE		Has to be set to 24 V DC at startup
FUNCTION EARTH		Connect to earth

4.1 Connection guidelines

The following section contains some guidelines regarding the connections, which should be followed to ensure the correct operation of the safety light curtain from the PSEN op2H-A series.

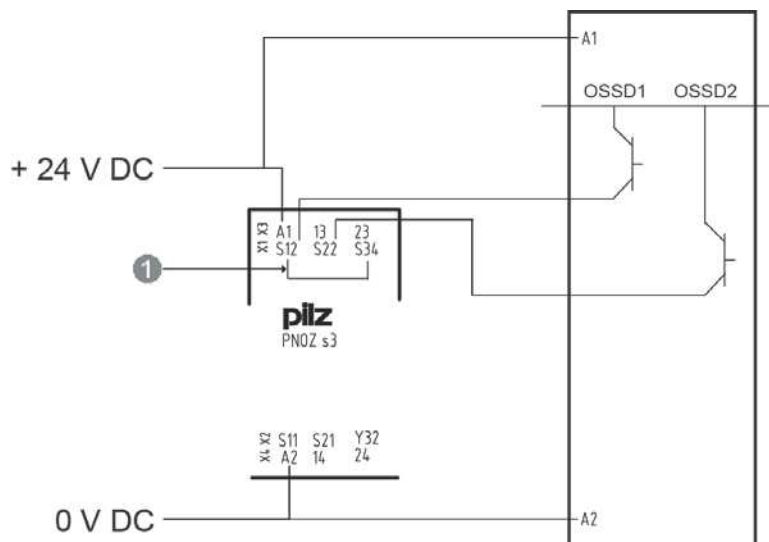
- Never place connection cable close to or in contact with cables featuring high voltage ratings and/or current fluctuations (e.g.: motor supply, inverters etc.).
- Never combine the OSSD wires from several safety light curtains into one multi-pole cable.
- The TEST wire must be connected to the light curtain's operating voltage via a pushbutton with N/O contact.
- Use the light curtain with protection class III with SEL/PELV external supplies for power supply.

 **The RESET button must be positioned so that the user can check the protected field during any test.**

 **The RESET/RESTART/ALIGN button must be positioned so that the user can check the protected field during all reset operations.**

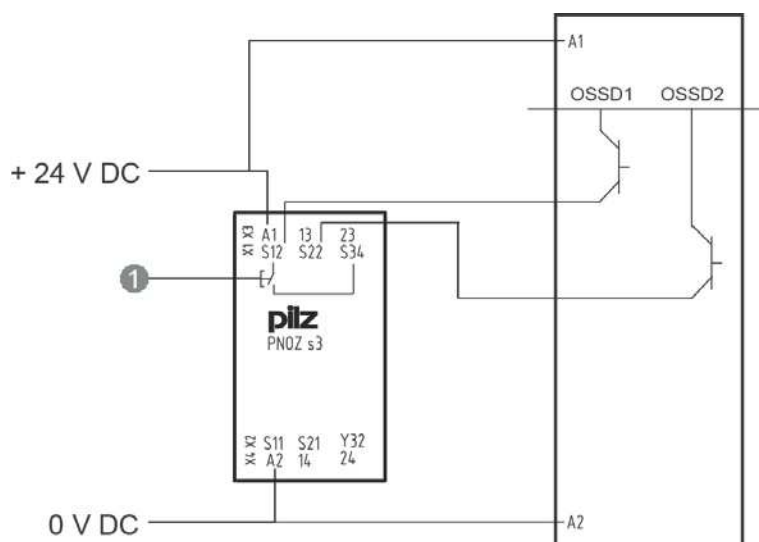
- The light curtain is already equipped with internal suppressors for overvoltage and overcurrent. We would advise against using additional components.

Example: Connection to the safety relay



 Automatic start

Fig. 20 – Connection to safety relay – automatic start



1 Manual start

Fig. 21 – Connection to safety relay – manual start

The diagrams show the connection between the safety light curtains and the safety relay PNOZ s3 in automatic start mode (Fig. 20) and monitored manual start mode (Fig 21).

- Avoid using varistors, RC circuits or LEDs in parallel to the relay inputs or in series connection to the OSSD outputs.
- The safety contacts of OSSD1 and OSSD2 may not be connected in series or in parallel, but must be used separately (Fig. 22).
- Should one of these configurations be used by mistake, the device switches to an output error condition (see Chapter 8).
- Connect both OSSDs outputs individually to the safety relay. Other configurations have a negative effect on the safety of the system and are not permitted.

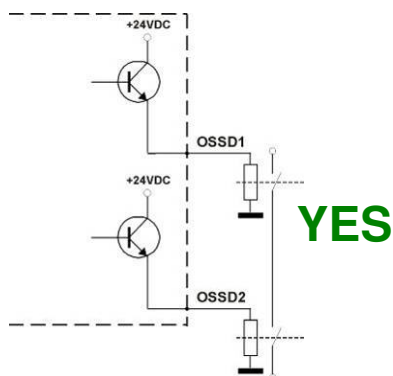


Fig. 22 – Correct OSSD signal load connection

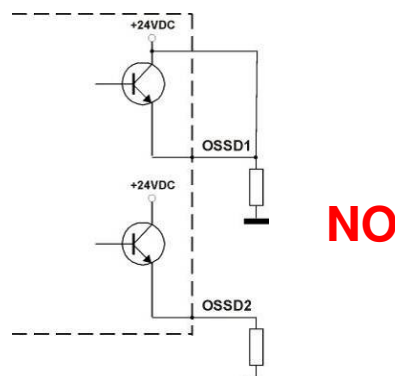


Fig. 23 – Incorrect OSSD signal load connection (I)

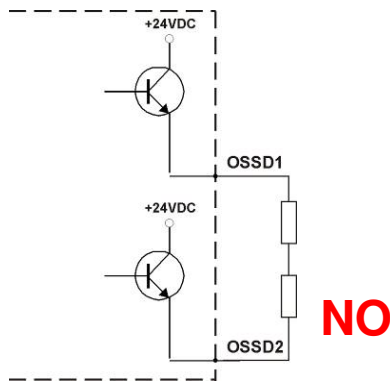


Fig. 24 – Incorrect OSSD signal load connection (II)

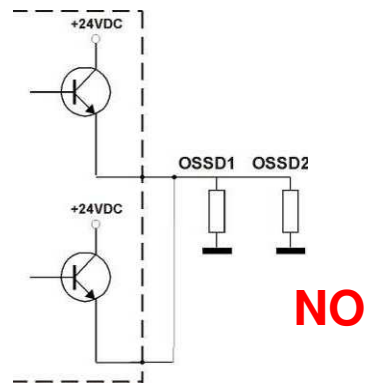


Fig. 25 – Incorrect OSSD signal load connection (III)

NOTE: The OSSDs are pulsed. The following diagram shows the time characteristic of the OSSDs.

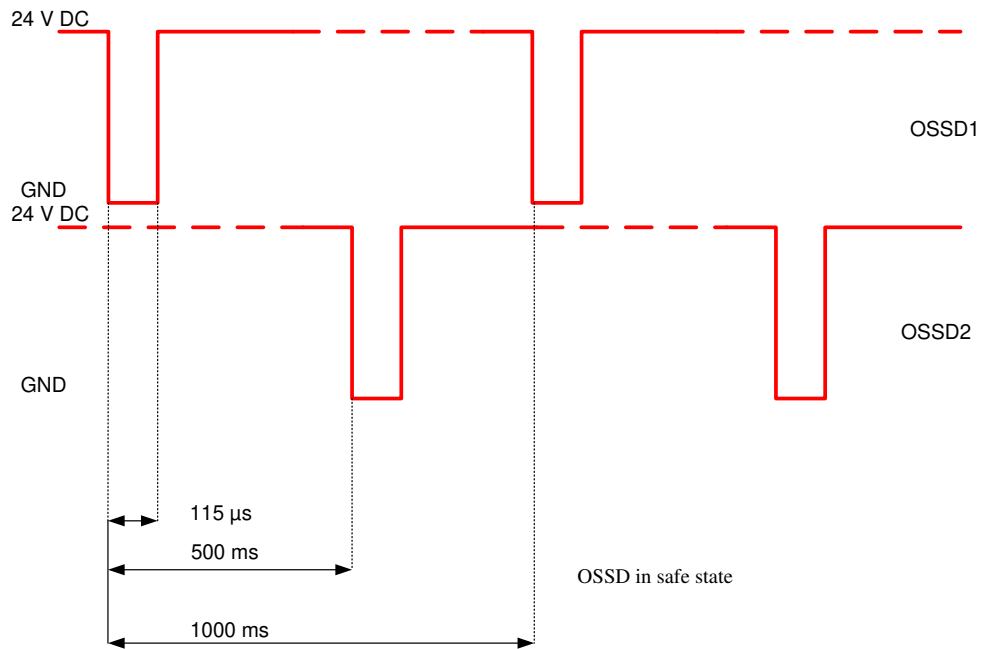


Fig. 26 – Time characteristic of the OSSDs

5 ALIGNMENT

The transmitter and receiver must be aligned to ensure the device operates correctly. Good alignment prevents the light curtain switching incorrectly due to dust or vibration. The optimum alignment is achieved when the optical axes of the first and last beam from the transmitter coincide with the optical axes of the corresponding elements on the receiver. The light curtain has two synchronisation beams. The lower synchronisation beam, the first beam in the protected field, is called SYNC1 and the synchronisation beam on the opposite side of the light curtain, the last beam in the protected field, is called SYNC2. The illustration shows that the first beam is on the lower edge of the light curtain, next to the LED display. The last beam is on the opposite side, next to the terminator cap.

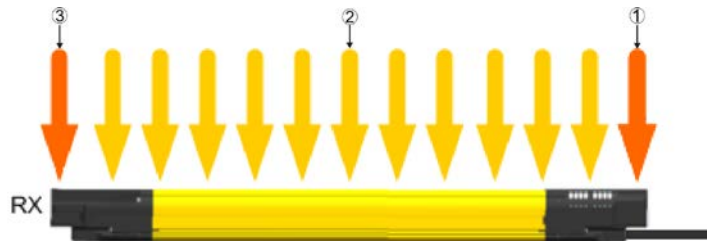


Fig. 27 – Beam description

1	=	First beam SYNC1
2	=	Beam of protected field
3	=	Last beam SYNC2

The alignment function can be activated by simultaneously switching 24 V at the input RESET/RESTART/ALIGN (Pin 3/ 12-pin connector) during startup. The activated alignment mode is shown when the second LED starts flashing (red) (see Fig. 28). Then the RESET/RESTART/ALIGN input can be switched without voltage again. When successful alignment has been reached, the light curtain is returned to normal operating mode by switching off and then on again.

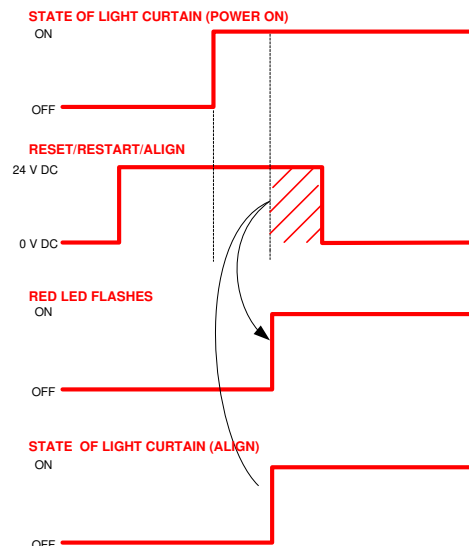



Fig. 28 – Alignment timings

In alignment mode, the light curtain is always in a safe state and the OSSD outputs are OFF. The quality and level of the alignment is determined via the signal strength of each individual beam in alignment mode. The two synchronization beams have a higher value level. The user can see the alignment quality from the LED state at the lower end of the receiver.

- A. Hold the receiver in a stable position and align the transmitter until the yellow SYNC1 LED goes out. This state confirms that the first synchronisation beam has been aligned.
- B. Rotate the transmitter around the axis of the lower lens until the yellow SYNC2 LED goes out.
- C. For precision adjustment, make minor movements of the transmitter and receiver to achieve the optimum quality .
- D. Attach both units firmly using the mounting brackets. Check that the LEVEL of the receiver does not decrease in quality and that the light axes are not interrupted. Then check that all LEDs on the LEVEL display go out, even if only one beam is interrupted. This test is conducted using a test object TP-30 corresponding to the resolution (see Chapter 2.2.5).
- E. Switch off the light curtain pair and then switch it back on in normal operating mode. The alignment level is also monitored by the display during normal operation (see Chapter 8.1). Once the light curtain has been aligned and fastened appropriately, the LED display proves perfect for checking the alignment and displaying any change in the ambient conditions (e.g. dust).

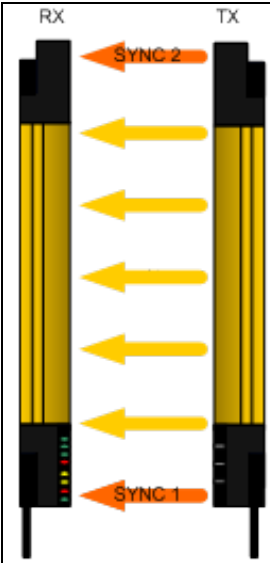




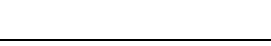





	Display	Configuration LED RX	Alignment status Alignment	Status of OSSD in normal operating mode
	No sync, check SYNC1		NONE	OFF
	SYNC1 aligned		NONE	OFF
	SYNC2 aligned		NONE	OFF
	One or more intermediate beams not aligned		NONE	OFF
	All light axes are aligned		POOR	ON
	All light axes are aligned			ON
	All light axes are aligned			ON
	All light axes are aligned			ON
	All light axes are aligned		EXCELLENT	ON

Fig. 29 –Status of the LED displays in alignment mode

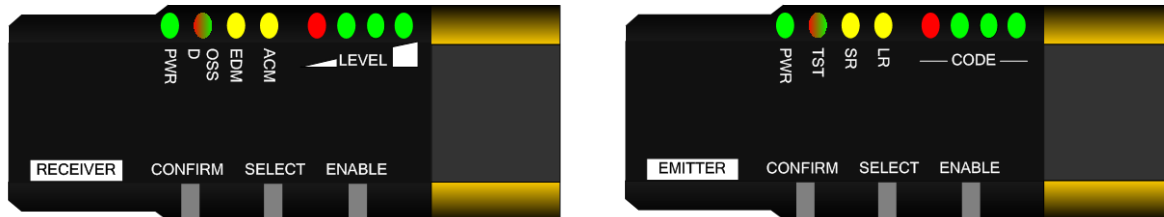
6 SETTING THE FUNCTIONS

In basic configuration mode you have the option to use the buttons and the LED interface (transmitter/receiver) to select basic functions/parameters.

Basic configuration mode

The user interface consists of 8 LEDs and 3 protected pushbuttons and enables the user to perform the basic configuration. The LEDs are the same LEDs used to display status in normal operating mode.

A plastic pen is provided (see Chapter 13), which the user must use to activate the pushbuttons, thus preventing unwanted access to the safety configuration.



Basic configuration steps

On the right-hand side of the operator panel at transmitter and receiver there is a settings interface, consisting of three pushbuttons. The interfaces give users the option to set the light curtain locally, without using the PSENOpt Configurator.

- CONFIRM button activates the BCM configuration mode
- SELECT button: The different functions are run through.
- ENABLE button: Activates and deactivates the currently selected function.

The individual steps are described below:

1. Press the **CONFIRM** button and keep it held down to switch to basic configuration mode.
2. The light curtain runs through a test cycle. With the transmitter the LEDs 2 and 3 light up one after the other, with the receiver the LEDs 2 to 8. The Power LED 1 is constantly lit.
After the test cycle is completed, the current configuration is displayed
3. Use the **SELECT** function to choose the function that is to be set. The LED for the selected function will flash.
4. Now configure the selected function by pressing the **ENABLE** button (LED lights/goes out).
5. Repeat steps 3 and 4 until the required configuration is displayed.
6. Press the **CONFIRM** button and keep it held down to save the new configuration.

6.1 Reset to factory configuration

The user has the option to re-establish the light curtain’s factory configuration by operating the pushbuttons as described below:

1. Press the CONFIRM button and keep it held down for at least 9 s (but not more than 30 s, so that the light curtain is not blocked)
2. The LEDs flash briefly, indicating that the light curtain has been reset to the factory configuration
3. After the reset has occurred, the light curtain resumes its normal operation with the factory configuration.



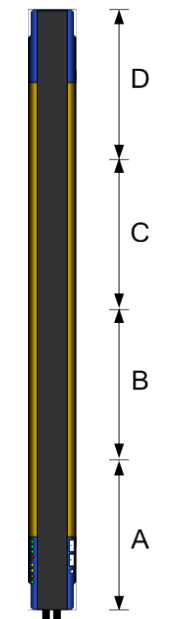





NOTE: Restoring the factory settings will delete the BCM configuration.



6.2 Function list

NOTE: The table highlights the default configuration in bold.

Legend for LED display in RX/TX function list	
○	LED off, LED is not relevant for the information in the “Function” column
●	LED off, LED is relevant for the information in the “Function” column
●	LED yellow, value in the “Setting” column is valid for the information in the “Function” column
●	LED red, value in the “Setting” column is valid for the information in the “Function” column
●	LED green, value in the “Setting” column is valid for the information in the “Function” column

List of RX functions in muting mode (LED 3 lights up yellow)			
Function	LED No.	Setting	LED status PWR OSSD EDM ACM LEVEL
Partial Muting	2 3	See the following table	
EDM	4	Activated	○ ○ ○ ● ○ ○ ○ ○
		Deactivated	○ ○ ○ ● ○ ○ ○ ○
Restart mode	5	Auto	○ ○ ○ ○ ● ○ ○ ○
		Manual	○ ○ ○ ○ ● ○ ○ ○
Muting direction	6	T (bidirectional)	○ ○ ○ ○ ○ ● ○ ○
		L (one-directional)	○ ○ ○ ○ ○ ● ○ ○
Muting timeout	7	10 min	○ ○ ○ ○ ○ ○ ● ○
		Infinite	○ ○ ○ ○ ○ ○ ● ○
Activation of override	8	Level	○ ○ ○ ○ ○ ○ ○ ●
		Edge	○ ○ ○ ○ ○ ○ ○ ●

Selection of partial Muting			
Muting zone	LED #	LED-Status	Light curtain zone
		PWR OSSD EDM ACM 	
A	Led 2 OFF Led 3 OFF		
A+B	Led 2 ON red Led 3 OFF		
A+B+C	Led 2 ON red Led 3 OFF		
A+B+C+D	Led 2 OFF Led 3 ON yellow		
B	Led 2 ON green Led 3 ON yellow		
C	Led 2 ON red Led 3 ON yellow		

List of TX functions			
Function	LED No.	Setting	LED status
			PWR TST SR LR — CODE —
Selection of operating range	3	Normal	
		Reduced	

7 FUNCTIONS

7.1 Restart function

If the beams detect an opaque object, the OSSD output switching elements will switch (i.e. the safety contacts will open, SAFETY conditions). The restart function enables the user to define how the light curtain returns from the safe state to normal operation.

There are two ways to restart the light curtain (i.e. close the OSSD safety contacts – SAFETY condition): automatic or manual restart.

Automatic restart: If an opaque object is detected, the light curtain switches to a SAFE CONDITION. If the object is then removed from the protected field, the light curtain will resume its normal operation.

The response time is the time that elapses between the object being introduced to the protected field and the OSSD achieving the OFF state (SAFETY); the reset time is the time it takes for the OSSD to switch to the ON state (SAFETY) after all the objects have been removed.

All these times are functions that are dependent on length, as illustrated below.

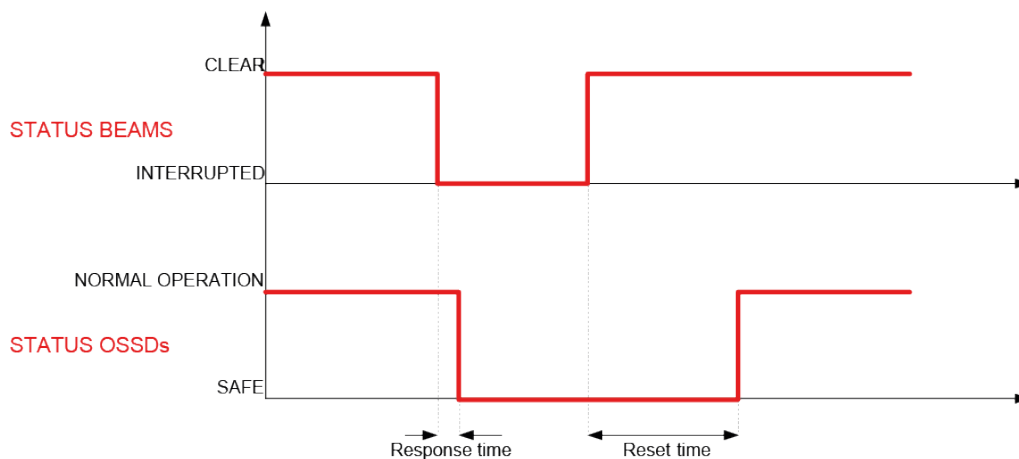


Fig. 30 – Restart timings (auto)

In automatic restart mode, the RESET/RESTART/ALIGN input (Pin 3 of the 12-pin M12 connector – RX-side) must not be activated.

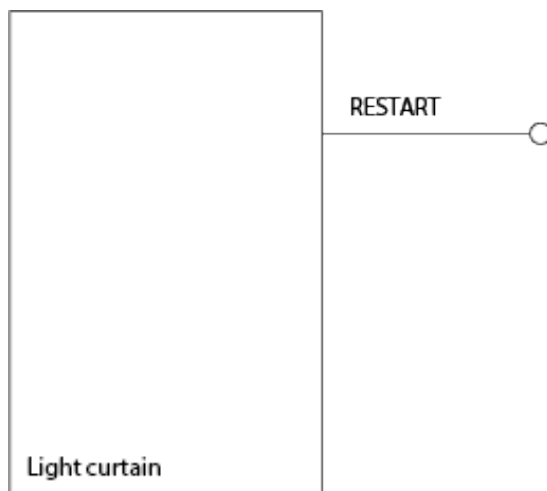


Fig. 31 – Restart connection (auto)

Manual restart: When the light curtain has detected an opaque object in the protected field, the light curtain does not resume its normal operation until the object has been removed from the protected field and the reset button has been operated.

The OSSD output switching elements switch back to normal operation when the RESTART signal voltage is removed again, and not after 500 ms. If the RESTART signal is present for longer than 5 s an error is generated, which blocks the light curtain.

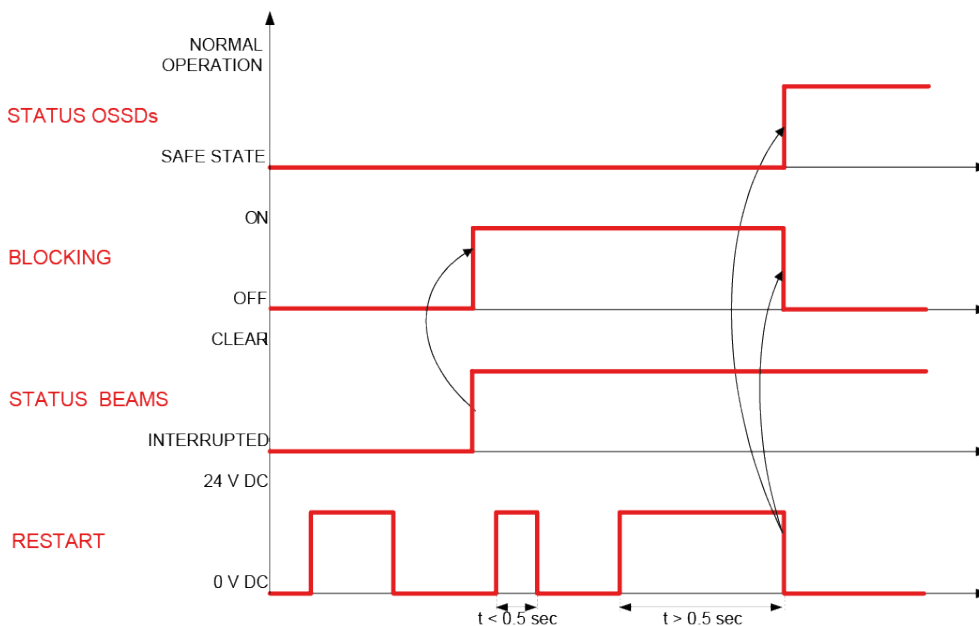


Fig. 32 – Restart timings (manual)

In manual restart mode, the RESET/RESTART/ALIGN input (Pin 3 of the 12-pin M12 connector – RX-side) must be connected to a 24 V DC N/O contact.

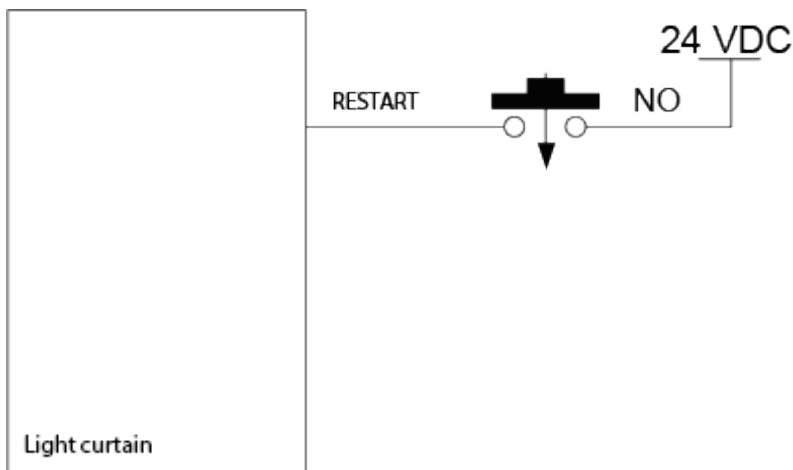


Fig. 33 – Restart connection (manual)

	<p>WARNING: Hazardous conditions and the reset mode should be assessed carefully. When access to danger zones is protected, automatic reset mode is potentially unsafe if it enables the operator to pass through the zone before the sensing area is active. In this case it will be necessary to use a manual restart or, for example, the manual restart on the relay PNOZ s3 (see Chapter 4.).</p>
--	---

7.3 Reset

If the light curtain is blocked in a fault state, you can restore normal operation by switching the light curtain on and off or by activating the RESET function (only with critical errors). To activate the RESET function, the RESET/RESTART/ALIGN connection (Pin 3 of the 12-pin connector) must be supplied with 24 V for at least 5 seconds. If the light curtain does not return to normal operating mode, the light curtain has to be switched off and on again. Errors in the internal connections can be cancelled this way.

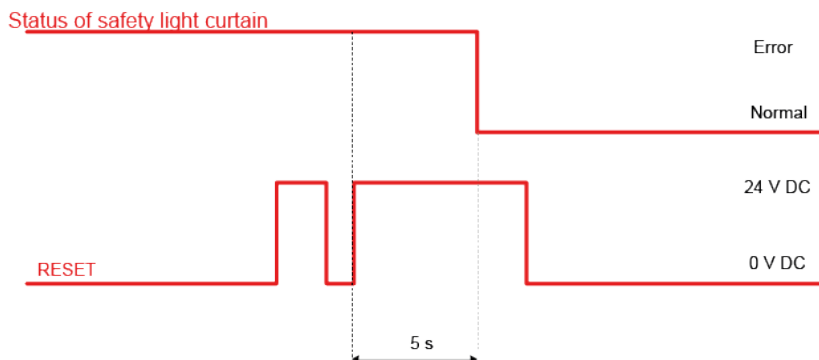


Fig. 35 – Reset timings

If the error has not been rectified, the light curtain will again switch to a blocked state.

7.4 EDM

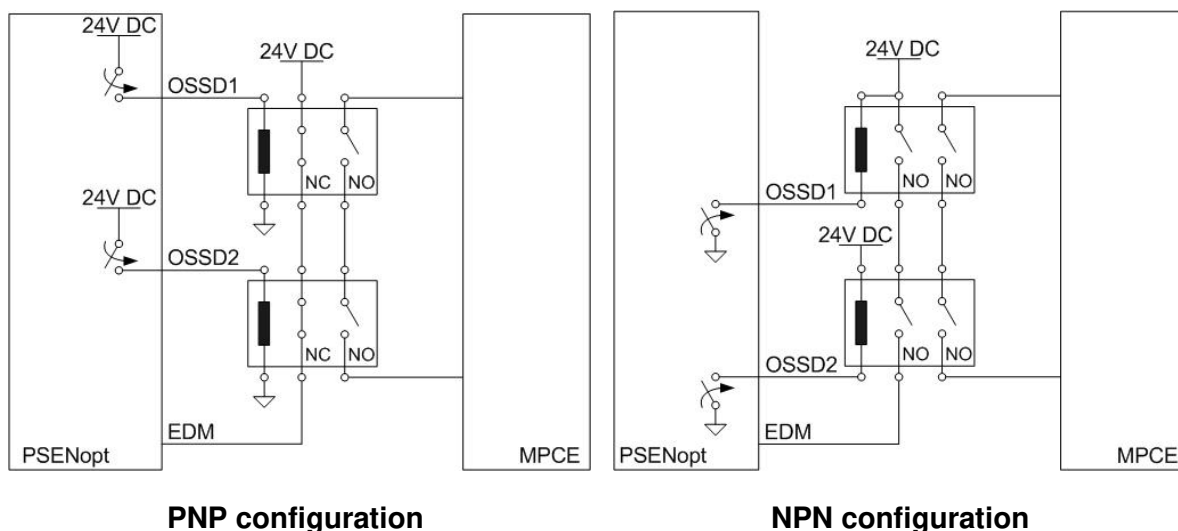
The external device monitoring function (EDM) monitors the external devices and checks the OSSD status.

EDM enabled:

If EDM is enabled in the PNP configuration, the EDM input (Pin 6 of the 12-pin M12 connector - RX) must be connected to a 24 V DC N/C contact on the device to be monitored. If the EDM is enabled in the NPN configuration, the EDM input (Pin 6 of the 12-pin M12 connector - RX) must be connected to a 24 V DC N/O contact on the device to be monitored.

NOTE: In normal operating mode, the third LED switched on in the user interface indicates that the function is active.

The following diagrams describe how to connect the EDM input in the event of a PNP and NPN configuration.



The function monitors the switching of the 24 V DC N/C contact, based on the OSSD status changes.



Fig. 36 – EDM timings

The EDM status is not equivalent to that of the OSSD: the timing diagram illustrates the relationship between cause (OSSD) and effect (EDM), with the maximum permitted delay.

$T_c \geq 350$ ms (time between the OSSD transition from OFF-ON and the EDM test)

$T_o \geq 100$ ms (time between the OSSD transition from OFF-ON and the EDM test)

(two different times for the mechanical, positive-guided contact)

EDM disabled:

If EDM is disabled, the EDM input may not be connected.

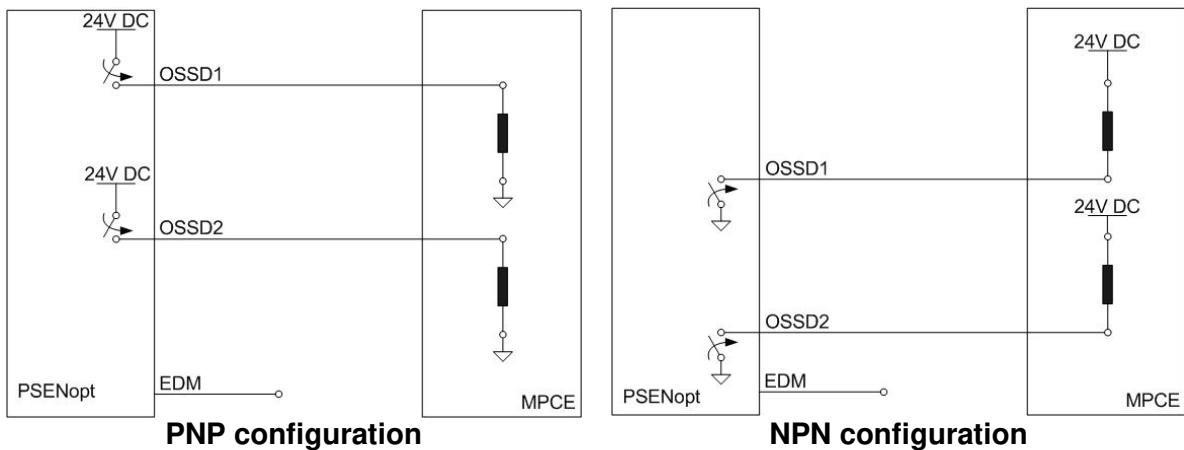


Fig. 37 – EDM connections

7.5 EDM selection

This function enables users to select or exclude monitoring of the external switching devices.

BCM configuration: EDM selection		PWR	OSSD	EDM	ADM	LEVEL
Activated	LED 4 ON yellow	●	●	●	●	▴
Deactivated	LED 4 OFF	●	●	●	●	▾

To increase the safety level when EDM is OFF when the light curtain is commissioned, ensure that the EDM input is not connected.

7.6 Reduced range

This function enables you to select the maximum operating range for the light curtain's assembly.

The table below summarises the different operating ranges, if the reduced operating range is changed.

Resolution 30 mm	TX
long range	20 m
short range	12 m

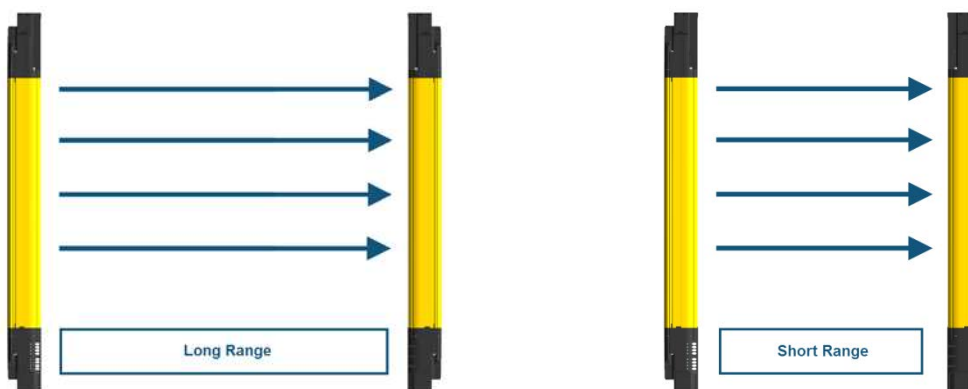


Fig. 38 – Reduced range

BCM configuration (TX-side): Reduced range		PWR	OSSD	EDM	ACM	LEVEL			
Long	LED 3 ON yellow	●	●	●	●	●	●	●	●
Reduced	LED 3 OFF	●	●	●	●	●	●	●	●

If long range is selected, the TX and RX can be installed at the maximum permitted operating range.

7.7 Muting

The muting function guarantees that the safety function is automatically disabled over all or part of the height of the detection zone, to enable specific, cyclical work operations to be carried out without having to stop the machine operation.

In accordance with safety requirements, the light curtain is equipped with two inputs for activating the muting function, MUTING1 and MUTING2.

The muting sensors must be able to detect the conveyed material (pallets, vehicles,...) based on their length and speed. Where there are variable conveyor speeds within the muting area, you must consider the effect this will have on the overall duration of the muting process.

- The muting function excludes the light curtain during operation and maintains the OSSD output switching elements in an activated state, based on the specific operating requirements (Fig. 39).

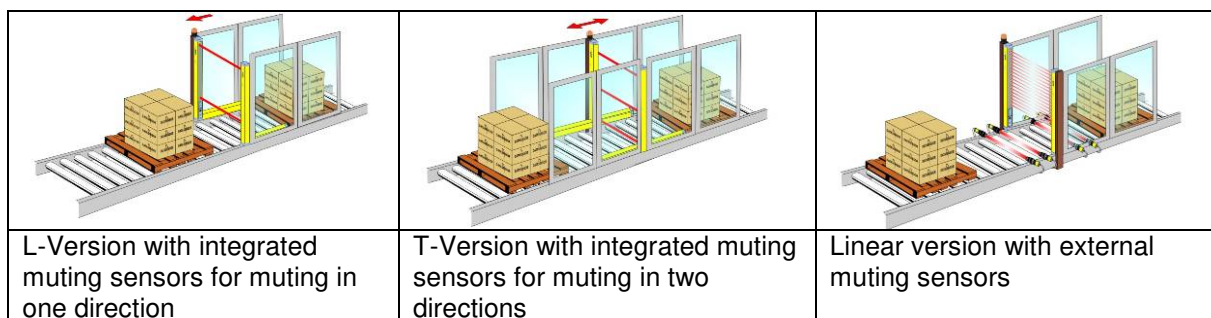


Fig. 39 – Application examples for the muting function

- In accordance with the applicable standards, the safety light curtain has two inputs (MUTING1 and MUTING2) to activate this function.
- This function is particularly suitable for cases in which an object, but not a person, needs to pass through the danger zone under certain conditions.
- It is important to note that the muting function represents a hazardous situation of the device. So it must be applied only in keeping with the necessary preventive measures.
- The muting sensors must be correctly positioned to avoid unintended muting becoming potentially dangerous for the operator.
- MUTING1 and MUTING2 cannot be activated simultaneously.
- The muting status is displayed via an external muting lamp (which can be connected to the light curtain via Pin 10 of the 12-pin M12 connector) and via various LEDs on the user interface. If the muting function is ON, the LAMP and LEDs start to flash.
- During installation, ensure that the lamp is positioned so that it is as visible as possible.
- If the external lamp is broken and/or not connected, a muting call will result in a SAFETY BLOCKING CONDITION and the relevant error message will be displayed.

	Particular attention should be paid to the choice of configuration, as an incorrect configuration can cause the muting function to operate incorrectly and reduce the safety level.
	The muting sensors must be arranged in such a way that the muting function cannot be activated by an operator who happens to pass through.

7.7.1 Disabling the muting function

The muting function can be enabled and disabled dynamically during operation of the PSEN op2H-A. When disabled, no muting call is accepted at the inputs MUTING X and the safety function is constantly active.

Users can deactivate the muting function during operation by applying 24 V at the DISABLE signal (Pin 7 of the 12-pin connector).

7.7.2 Muting display devices

The corresponding display device (lamp) must be connected in order to use the muting function. If this device is not present, the light curtain will switch to a blocked state due to a defect.

Both incandescent lamps and LED lamps are permitted. If you are using an LED lamp, make sure that the connection has the right polarity.

When the lamp is switched on, a lamp TEST is carried out as part of each cycle, to ensure that any functional failure is detected. If the lamp is found to be broken, the light curtain will switch to a safe state and a corresponding message is shown on the display (see Chapter 10 for further information on the lamp).

7.7.3 Typical muting application and sensor connection

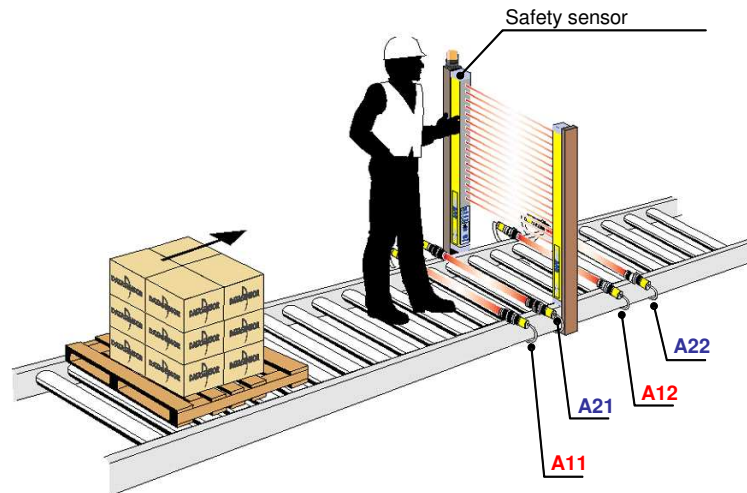


Fig. 40 – Typical muting application

The diagram above shows a typical muting application: the protection device installed on the conveyor must allow the package to pass through but not the operator. The light curtain temporarily suspends its safety function when the sensors A11, A21, A12, A22 are activated in the correct sequence.

These may be optical or mechanical sensors that switch 24 V when the object is detected.

7.7.4 Muting direction

The light curtain can be used for bidirectional muting (T-type, four sensors) as well as one-directional muting (L-type, two sensors).

- T-muting is used when objects can move through the light curtain in both directions.
- L-muting is used when objects move only in one direction.

In BCM mode the maximum activation delay between MUTING1 and MUTING2 (T12max) is 4 seconds

T-Muting

With T-type operation, the device switches to the muting function if the signal from the MUTING2 input switches within a fixed T12max, after the MUTING1 signal has switched (or vice versa). The muting function ends as soon as the signal at MUTING1 or MUTING2 goes low. Once this time has elapsed, if users wish to switch to muting status they will need to deactivate the muting input and start the sequence again.

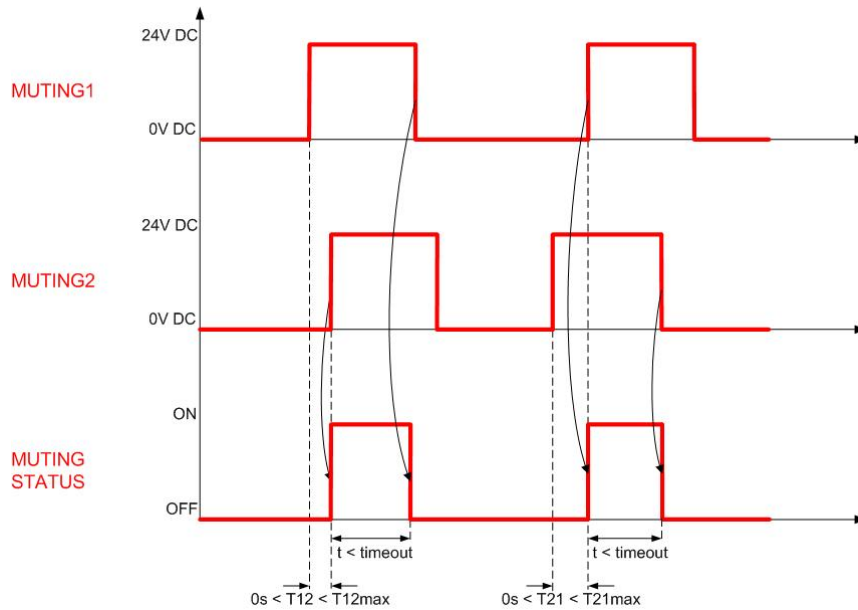


Fig. 41 – T muting timings

The sensors labelled A1/A2 are connected to the muting input (MUTING1) and the sensors labelled B1/B2 are connected to the MUTING2 input. Sensors ending in “1” are on the same side of the light curtain and therefore on the opposite side to the sensors ending in “2”.

“D” stands for the distance at which the sensors A1/A2 or B1/B2 must be installed and depends on the package length (L):

$$D < L$$

“d1” stands for the maximum distance required between the muting sensors and depends on the package speed (V):

$$d1_{\max} [\text{cm}] = V [\text{m/s}] * T12 [\text{s}] * 100,$$

“d2” stands for the maximum distance required to accept a muting request and depends on the package speed (V):

$$d2_{\max} [\text{cm}] = V [\text{m/s}] * T12 [\text{s}] * 100,$$

“T12” stands for the activation delay between MUTING1 and MUTING2.

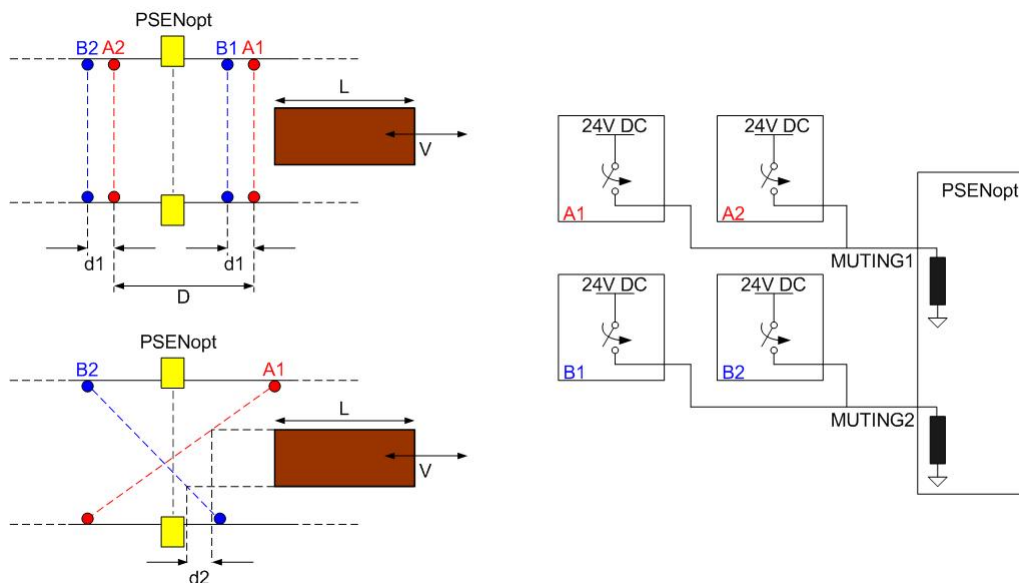


Fig. 42 – T-Muting connection

L-Muting

With L-muting, the light curtain is muted if the input signals switch to 24 V DC in accordance with a certain sequence: MUTING1 must be activated first; only then can MUTING2 be activated.

If MUTING2 should activate before MUTING1, the device will not switch to muting mode; “T12” represents the activation delay between MUTING1 and MUTING2.

The muting function ends once the time has elapsed, which corresponds to a multiple of the activation delay between the two sensors (this time corresponds to $m \times T12$). The value “m” (multiplier T12) must be selected by the user. The value is preset with $m = 2$.

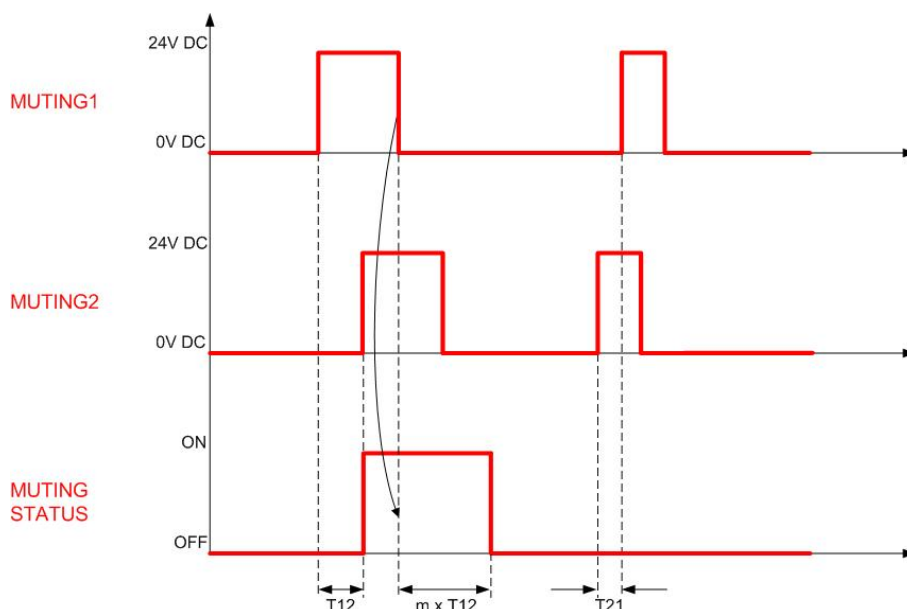


Fig. 43 – L-muting timings

The sensor labelled A is positioned furthest away from the light curtain, which is why its beam is recorded first. With reference to the diagram below and in consideration of the fact that the package only passes from right to left, sensor B cannot be recorded first. If this should happen, the light curtain is not muted.

“V” indicates a constant velocity. As a result, “d1” can be calculated in accordance with the following formula:

$$d1 [cm] = V [m/s] * T12 [s] * 100$$

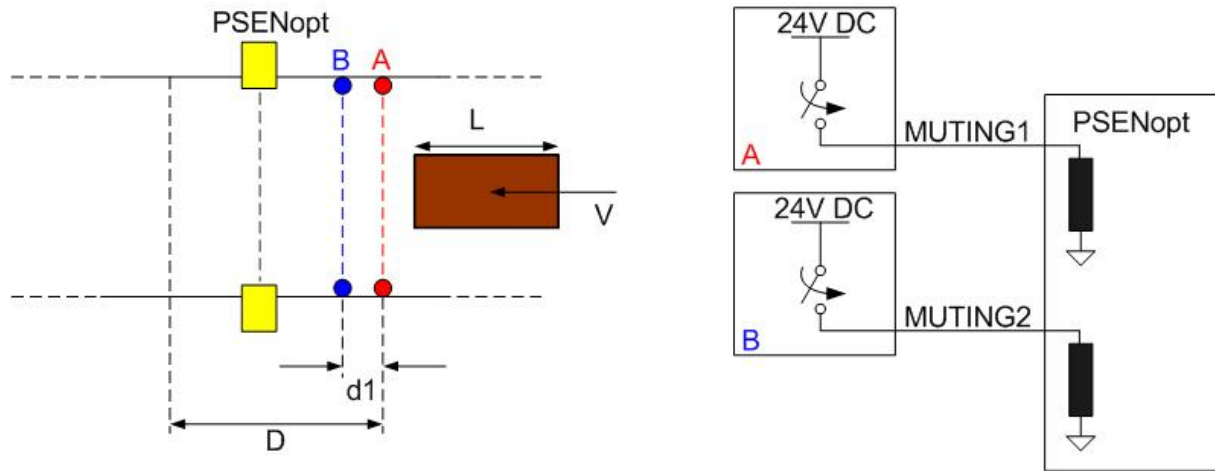


Fig. 44 – L-Muting connection

BCM configuration: Muting direction		PWR	OSSD	EDM	ACM	LEVEL	
T (bidirectional)	LED 6 ON green	●	●	●	●	●	●
L (one-directional)	LED 6 OFF	●	●	●	●	●	●

7.7.5 Muting timeout

The muting timeout describes the time for the maximum duration of the muting function; once the timeout has elapsed, muting is ended.

The user has the option to set this time.

He can select a timeout to be 10 minutes or infinite; "infinite" means that the muting timeout may potentially never end: as long as the muting conditions are present, the muting function will be maintained.

NOTE: This does not comply with the standard IEC 61496-1 and the user is informed of this fact via a message

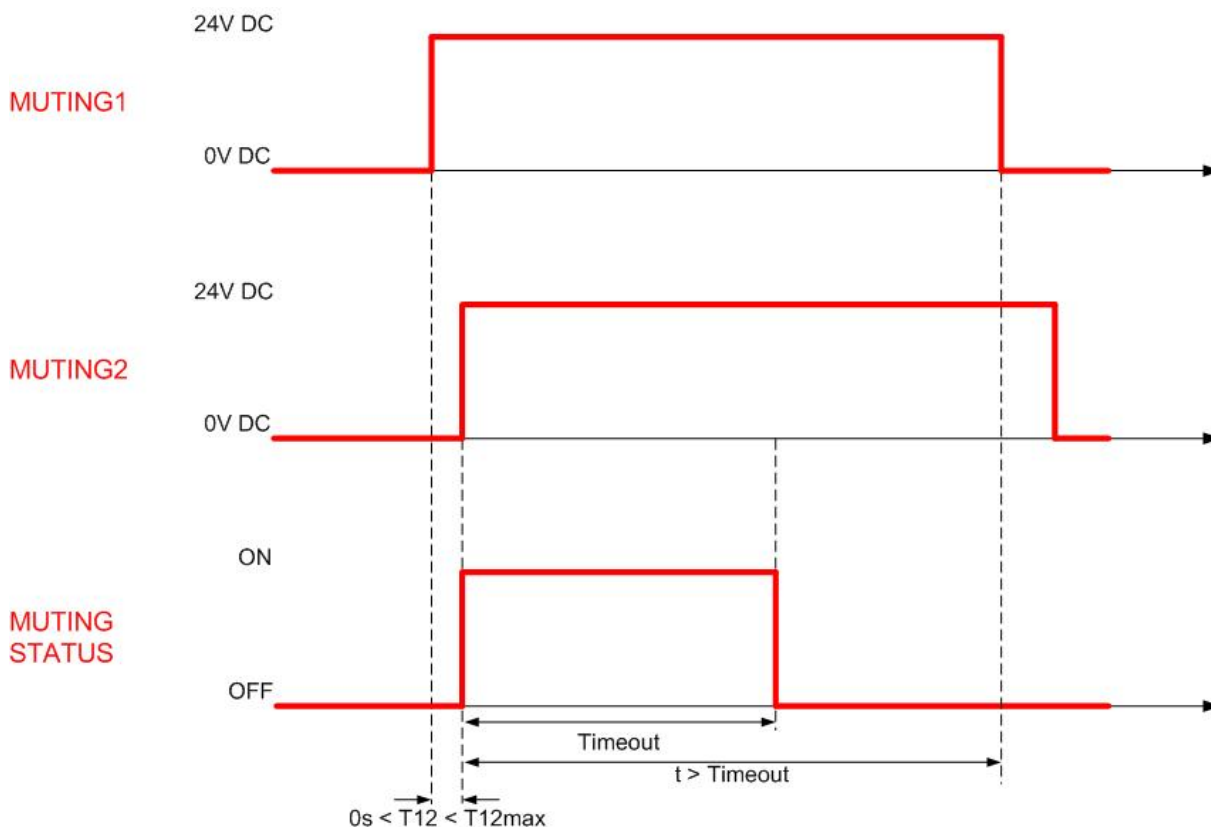


Fig. 45 – Muting timeout

BCM configuration: Muting timeout		PWR	OSSD	EDM	ACM	LEVEL	
10 min	LED 7 ON green	●	○	○	○	○	●
Infinite	LED 7 OFF	●	○	○	○	○	●

NOTE: The infinite timeout option does not comply with the standard IEC 61496-1 and the user is warned accordingly.

7.7.6 Partial muting

The muting type can be configured: total or partial muting. Partial muting can prove useful when the user wishes to limit the effects of the muting function exclusively to the selected zones. Each of the zone A-D includes a quarter of the light curtain's length. With a light curtain with a length of 40 cm, this is 15 cm.

Muting zone	Zone at the light curtain	LED							
		PWR	OSSD	EDM	ACM	LEVEL			
A		Led 2 OFF Led 3 ON	●	●	●	●	●	●	●
A+B		Led 2 ON Green Led 3 OFF	●	●	●	●	●	●	●
A+B+C		Led 2 ON Red Led 3 OFF	●	●	●	●	●	●	●
A+B+C+D		Led 2 OFF Led 3 ON Yellow	●	●	●	●	●	●	●
B		Led 2 ON Green Led 3 ON Yellow	●	●	●	●	●	●	●
C		Led 2 ON Red Led 3 ON Yellow	●	●	●	●	●	●	●

7.8 Override

The override function allows the user to disable the safety functions if the machine needs to be restarted, even though one or more of the light curtain beams have detected an object in the protected field. For example, a typical application would be to examine recurring blockages more precisely and to rectify the cause. These may be work materials between the light curtain's transmitter and receiver, which trigger the light curtain.

The override's redundant inputs must be connected to a 24 V DC N/O contact and an earthed N/O contact.

In accordance with the guidelines, the light curtain is equipped with two override activation inputs: OVERRIDE1 and OVERRIDE2 (respectively, Pin 4 of the 12-pin M12 connector and Pin 9 of the 12-pin M12 connector – of the receiver).

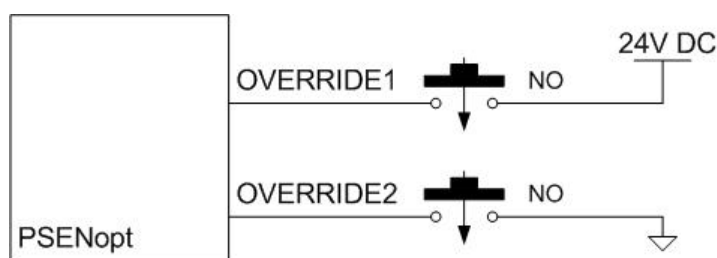
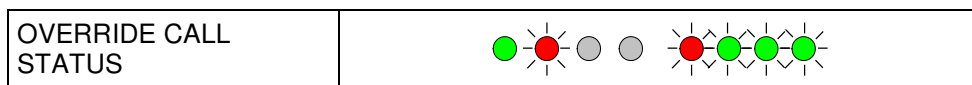


Fig. 46 – Override connection

The condition for the override is that the light curtain must be in a SAFE STATE and at least one muting sensor must have been interrupted.

If this condition is met, the user interface shows “override call status” and both the red LED on the OSSDs and the LEDs for the alignment function flash.



As a result, the override request will only be accepted if the signals at the OVERRIDE X inputs comply with the timings shown below.

The override function is ended automatically if any of the following conditions is present:

- All muting sensors are deactivated (with a T-muting configuration).
- All muting sensors are deactivated and no beams are interrupted (with an L-muting configuration).
- The preset time limit has elapsed.
- The requirements for activation are no longer met (e.g. an override input is deactivated).

7.8.1 Override mode

It is possible to activate the override inputs: Level or edge.

As shown in the diagram below, the two types of activation sequence for the override are recorded in the external inputs:

- **Activated by level:** The override remains activated until both contacts are closed and at least one muting sensor has been interrupted.
OVERRIDE STATE: This is an output signal which provides the user with information as to whether the override inputs are active and the override conditions are present.

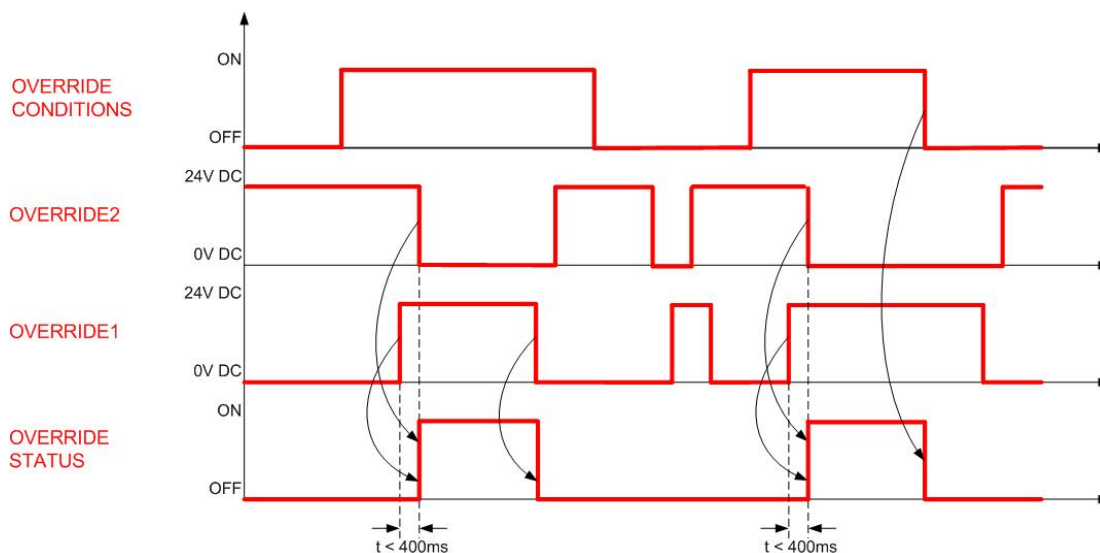


Fig. 47 – Override timings (activated by level)

- Activated by edge:** When the contacts are closed, the override remains activated until at least one muting sensor has been interrupted. In this case, the override status is also maintained if the override contacts are opened. The device switches the override status if any of the following events occurs:
 - The muting sensors are deactivated (T-Muting) or the muting sensors are deactivated AND no beams are interrupted (L-Muting).
 - The timeout time elapses.

OVERVERRIDE STATE: This is an output signal which provides the user with information as to whether the override inputs are active and the override conditions are present.

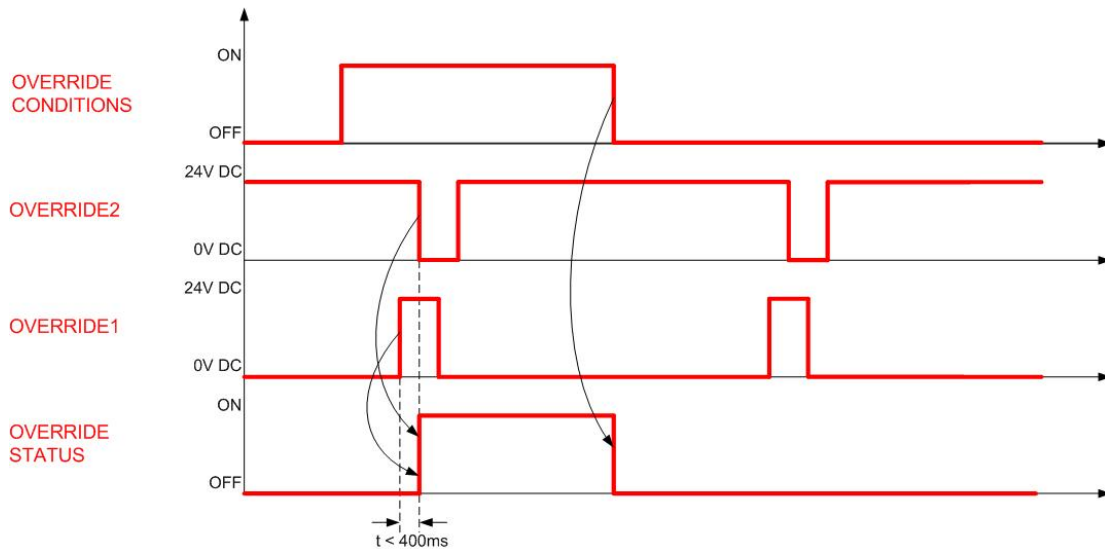


Fig. 48 – Override timings (activated by edge)

BCM configuration: Override mode		PWR	OSSD	EDM	ACM	LEVEL
Level	LED 8 ON green	●	●	●	●	●
Edge	LED 8 OFF	●	●	●	●	●

8 DIAGNOSTICS

8.1 Status of LEDs

On the bottom left-hand side of the light curtain 8 LEDs help users to monitor and check the state of the light curtain in alignment mode, in normal mode and when troubleshooting. The LEDs can be used to recognise the configuration that has been set via the pushbuttons.

Receiver side (RX):

		Receiver side (RX):				Meaning of LED				
		PWR	OSSD	EDM	ACM	LEVEL			● Off	● On
		●	●	●	●	●	●	●	☀ Flash	○ Indifferent
				Sync		Fault Code				
Operating mode of light curtain	Information	LED DISPLAY								Suggested action
Alignment	Not aligned	●	●	●	●	●	●	●	●	
	First synchronisation beam linked	●	●	●	●	●	●	●	●	
	Last synchronisation beam linked	●	●	●	●	●	●	●	●	
	Minimum signal level	●	●	●	●	●	●	●	●	
	Maximum signal level	●	●	●	●	●	●	●	●	
Normal operating mode Manual restart only	Interlock free beams	●	●	●	●	●	●	●	●	User can restart the device by activating the RESTART in normal operating mode.
	Interlock interrupted beams	●	●	○	○	●	●	●	●	User must clear protected field before activating the RESTART.
Normal operating mode	OSSD ON (maximum alignment)	●	●	○	○	●	●	●	●	
	Signal level at beams	●	●	○	○	●	●	●	●	
		None	●	●	○	○	●	●	●	●
Insufficient		●	●	○	○	●	●	●	●	
Low		●	●	○	○	●	●	●	●	
Good		●	●	○	○	●	●	●	●	
Best	●	●	○	○	●	●	●	●		
EDM active		●	○	●	○	○	○	○	○	

Normal operating mode Muting only	Muting active		If the OSSDs switch off unintentionally and during active muting, check the partial muting configuration.
	Override active		
	Override status		Activate the override button to bridge OSSDs to light
	Override timing error		Check and repeat the override activation sequence. Check the override connections.
	Lamp error		Check the lamp connections and check for any potential defects on the lamp.
Error information	OSSD error		Activate RESET. If the problem should persist, please contact Pilz customer services.
	Microprocessor error		Activate RESET. If the problem should persist, please contact Pilz customer services.
	Lens error		Activate RESET. If the problem should persist, please contact Pilz customer services.
	EDM error		Activate RESET. Check the EDM feedback line and the EDM configuration.
	Restart error		Check connection RESTART /RESET/REALIGN.
	Communication error		Activate RESET. Check the cascading connection and check that the terminator cap is installed correctly.
	BCM Configuration error		Perform basic configuration again. If the problem should persist, please contact Pilz customer services.

	Critical error		Switch light curtain on/off. If the problem should persist, please contact Pilz customer services.
	Supply error		Check the power supply connection. If the problem should persist, please contact customer services.

A critical error cannot be eliminated via a RESET.

The light curtain must be switched on and off. If the error should persist, please contact Pilz customer services.

Transmitter side (TX):

			Meaning of LED
Operating mode of light curtain	Information	LED DISPLAY	Suggested action
Normal operating mode	Light beams - reduced range		
	Light beams - long range		
	Test		Check the wiring of the TEST.
	Light beams		
Error	Microprocessor error		Activate RESET. If the problem should persist, please contact Pilz customer services.
	Lens error		Activate RESET. If the problem should persist, please contact Pilz customer services.
	BCM configuration error		Perform basic configuration again. If the problem should persist, please contact Pilz customer services.
	Communication error		Activate RESET. Check the cascading connection and check that the end cap is installed correctly.
	Critical error		Switch light curtain on/off. If the problem should persist, please contact Pilz customer services.

A critical error cannot be eliminated via a RESET.

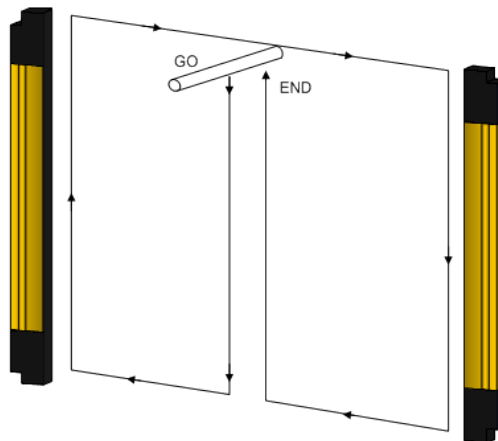
The light curtain must be switched on and off. If the error should persist, please contact Pilz customer services.

9 REGULAR CHECKS AND MAINTENANCE

9.1 REGULAR CHECKS

Perform the following checks once a day

- The light curtain remains in a safe state (OSSDs off).
 - The beams are interrupted across the whole area of the protected field using a test object (test rod) (TP-30) with an appropriate resolution, in accordance with the following diagram.



- Is the light curtain aligned correctly?
 - Press gently on the side of the product in both directions. The red LED must not light during this process.
- Activate the TEST function on the TX side.
 - The OSSD outputs are opened (red LED, OSSD on the RX side, ON and stop of the controlled machine).
- The response time to the machine STOP, including the response time of the light curtain and machine, are within the limit values defined for calculating the safety distance (see Chapter 2.2).
- The safety distance between the danger zones and the light curtain must comply with the details specified in Chapter 2.2.
- Access and exposure of persons between the light curtain and hazardous machine components must be prevented.
- It is not possible to access the machine's danger zones from an unprotected side.
- In order to guarantee that the light curtain remains in NORMAL FUNCTION MODE for at least 10-15 minutes and, after positioning the specific test object in the protected field, stays in a SAFE STATE for the same time span, there must be no interference from external light sources.
- Check that all additional functions comply by activating them several times under different operating conditions.

9.2 MAINTENANCE

The safety light curtain in the PSEN op2H-A-series does not require any special maintenance.

The front optical protective surfaces should be cleaned regularly to prevent any reduction in the operating range.

Use moist cotton cloths. Do not apply excessive pressure or the surfaces may become tarnished.

The following materials should **not** be used to clean plastic surfaces or paintwork on the light curtain:

- Alcohol and solvents;
- Woollen cloths or synthetic materials;
- Paper or other abrasive materials.

10 TECHNICAL DETAILS

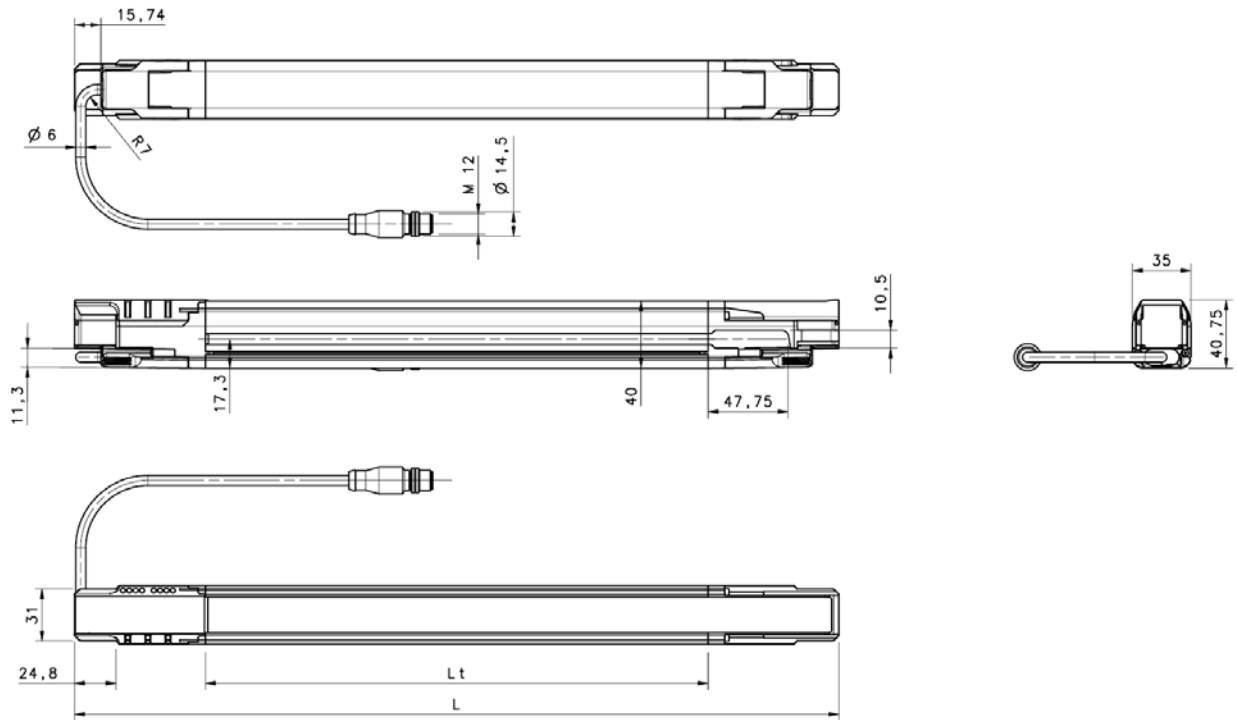
Electrical data	
Operating voltage:	24 V DC $\pm 20\%$
Current consumption transmitter (TX):	Max. 3 W
Current consumption receiver (RX):	5 W max (without load)
Outputs:	2 PNP
- Short circuit protection:	1.4 A max
- Output current:	0.5 A max. at each output
- Output voltage – Status ON:	Operating voltage – 1 V min
- Output voltage – Status OFF:	0.2 V max.
- Capacitive load:	2.2 μ F at 24 V DC max
Response times:	See table below
Reset time:	100 ms
Reset time when Sync interrupted:	2 Sec.
Height of protected field:	300..1800 mm
Category:	Type 2 (ref. to EN 61496-1) SIL 1 (ref. to EN 61508) SIL 1 (ref. to EN 62061) PL c and Cat. 2 (ref. to EN ISO 13849-1:2008) PFHd [1/h] = 1.04E-08 MTTFd [years] = 273
Auxiliary functions:	Test; manual/automatic restart; EDM; reset; muting
Protection class:	Class III (see Ch. 4.1)
Current for external lamp:	20 mA min.; 300 mA max.
Connections:	- M12 12-pin + M12 5-pin for receiver (muting model) - M12 5-pin for transmitter (for both models)
Cable length (for supply):	50 m max.
Optical data	
Transmitter light (λ):	Infra-red, LED (950 nm)
Resolution:	30 mm
Operating range:	0.2...20 m for 30 mm
Ambient brightness:	IEC-61496-2
Environmental data and mechanical data	
Operating temperature:	0...+ 50 °C
Storage temperature:	- 25...+ 70 °C
Temperature class:	T6
Humidity:	15...95 % (non-condensing)
Protection type:	IP 65 (EN 60529)
Vibration:	- Amplitude 0.35 mm, - Frequency 10 ... 55 Hz - 20 sweeps per axis, - 1 octave/min. (EN 60068-2-6)
Max. acceleration:	10 g (EN 60068-2-29)
Housing material:	Varnished aluminium (yellow RAL 1003)
Front surface material:	PMMA
Terminator cap material:	PBT Valox 508 (RAL 7021)
Cover material:	PC LEXAN
Weight:	1.35 kg per running metre per individual unit

11 LIST OF AVAILABLE MODELS

	Protected field height	No. of beams	Response time	Resolution	Test rate Rt ¹⁾	Demand rate Rd ¹⁾
Model	mm		ms	mm	1/s	1/min
PSEN op2H-A-30-030/1	300	16	13	30	77	46
PSEN op2H-A-30-045/1	450	24	14	30	71	43
PSEN op2H-A-30-060/1	600	32	15	30	67	40
PSEN op2H-A-30-075/1	750	40	16	30	63	38
PSEN op2H-A-30-090/1	900	48	17	30	59	35
PSEN op2H-A-30-105/1	1050	56	18	30	56	33
PSEN op2H-A-30-120/1	1200	64	19	30	53	32
PSEN op2H-A-30-135/1	1350	72	19	30	53	32
PSEN op2H-A-30-150/1	1500	80	20	30	50	30
PSEN op2H-A-30-165/1	1650	88	21	30	48	29
PSEN op2H-A-30-180/1	1800	96	22	30	45	27

¹⁾: The following applies for EN ISO 13849-1:2008 Category 2: Demand mode must be $\leq 1/100$ of the test rate.

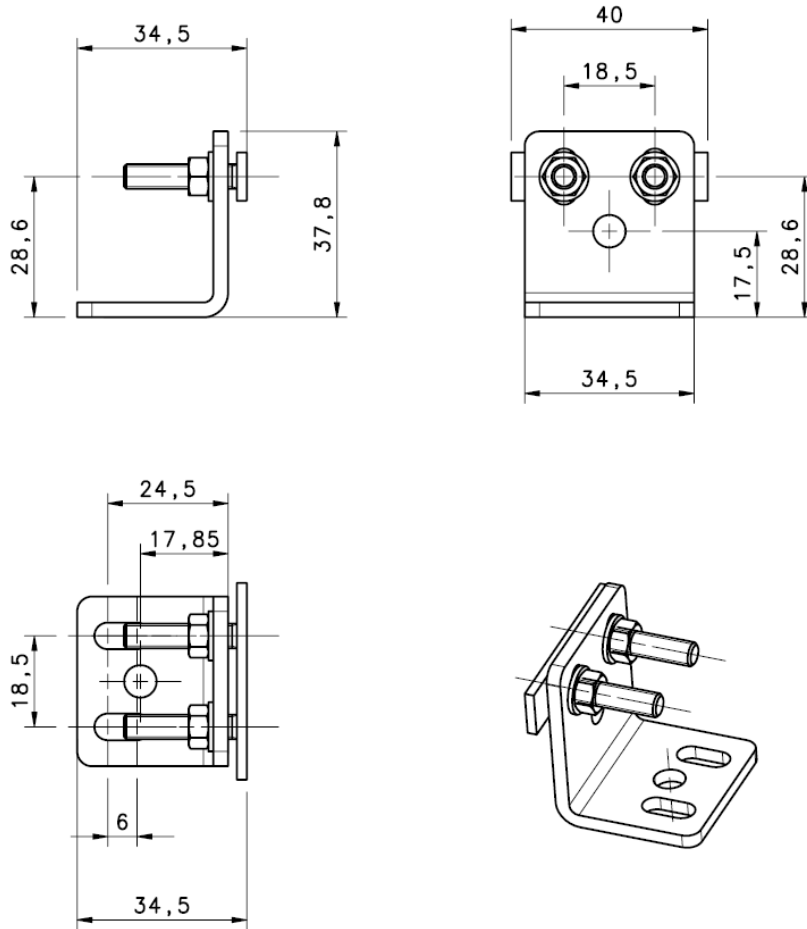
12 DIMENSIONS



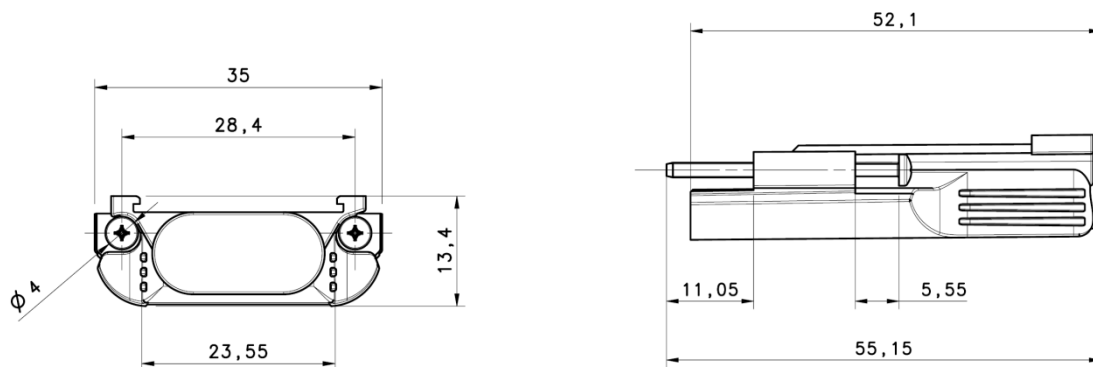
Model	L _t (mm)	L (mm)
PSEN op2H-A-30-030/1	150	306.3
PSEN op2H-A-30-045/1	300	456.3
PSEN op2H-A-30-060/1	450	606.3
PSEN op2H-A-30-075/1	600	756.3
PSEN op2H-A-30-090/1	750	906.3
PSEN op2H-A-30-105/1	900	1056.3
PSEN op2H-A-30-120/1	1050	1206.3
PSEN op2H-A-30-135/1	1200	1356.3
PSEN op2H-A-30-150/1	1350	1506.3
PSEN op2H-A-30-165/1	1500	1656.3
PSEN op2H-A-30-180/1	1650	1806.3

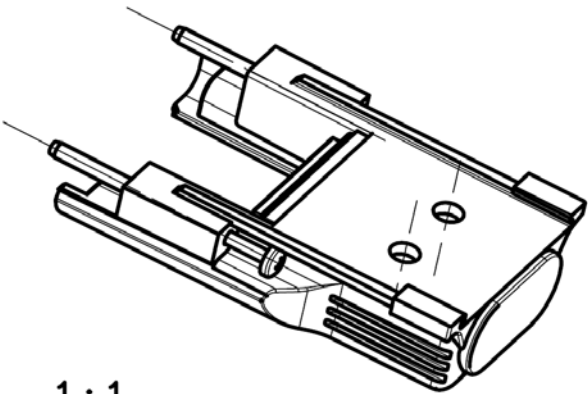
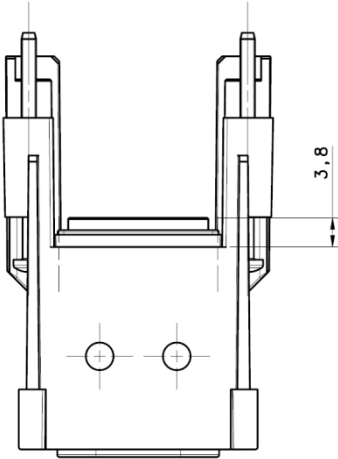
13 FITTINGS

Fastening bracket



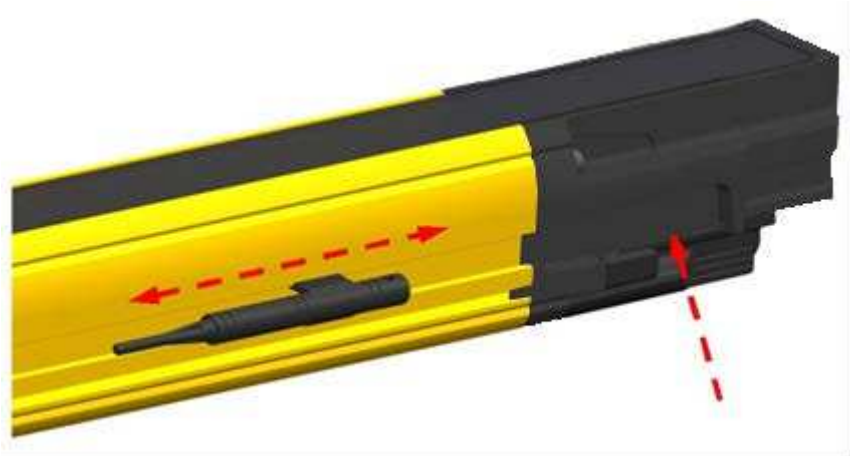
Terminator cap (fixed to the light curtain)





1 : 1

Tool for BCM configuration

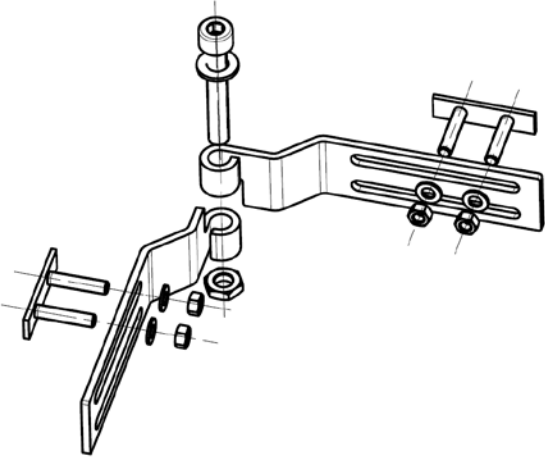
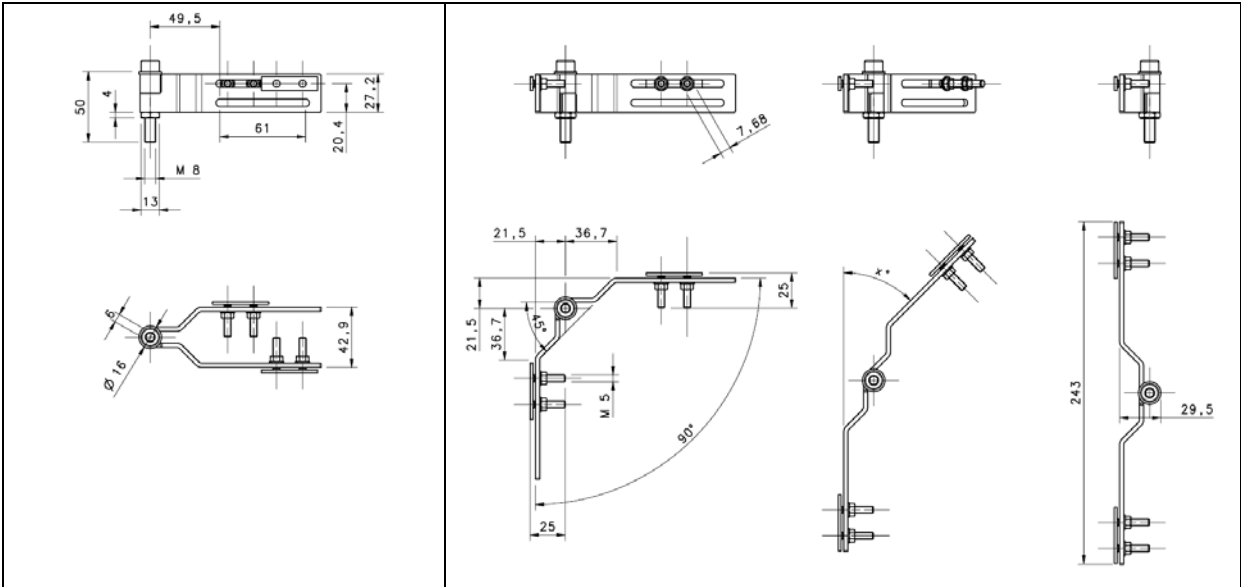


When not in use, the tool for the BCM configuration can be slotted into the profile groove or into the upper section of the light curtain.

14 ACCESSORIES

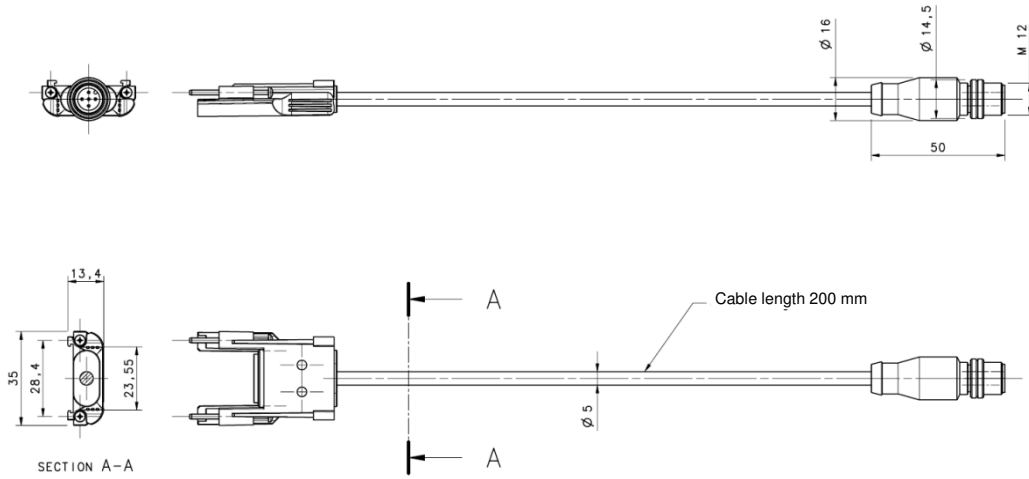
14.1 Rotating Mounting Bracket

Description	Order number
PSEN op cascading bracket	631 061

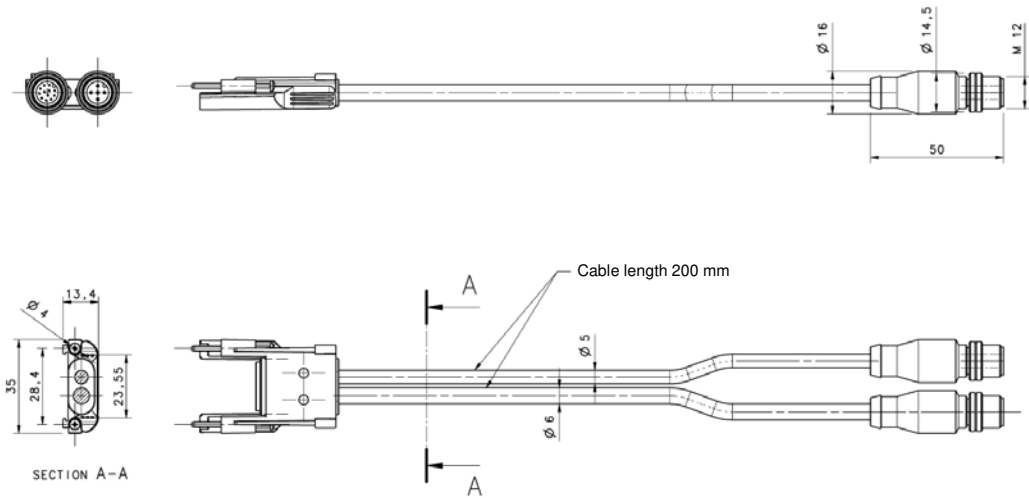


14.2 Connection cable

Description	Order Number
PSEN op pigtail emitter	631 055



Description	Order Number
PSEN op pigtail receiver m	631 057



14.3 Axial connection cable, unshielded

Description	Length (m)	Pins	Order number
PSEN op cable axial M12 4-pole 3 m	3	4	630 300
PSEN op cable axial M12 4-pole 5 m	5	4	630 301
PSEN op cable axial M12 4-pole 10 m	10	4	630 302
PSEN op cable axial M12 4-pole 30 m	30	4	630 296
PSEN op cable axial M12 4-pole 50 m	50	4	630 362
PSEN op cable axial M12 5-pole 3 m	3	5	630 310
PSEN op cable axial M12 5-pole 5 m	5	5	630 311
PSEN op cable axial M12 5-pole 10 m	10	5	630 312
PSEN op cable axial M12 5-pole 20 m	20	5	630 298
PSEN op cable axial M12 5-pole 30 m	30	5	630 297
PSEN op cable axial M12 5-pole 50 m	50	5	630 364
PSEN op cable axial M12 12-pole 3 m	3	12	631 080
PSEN op cable axial M12 12-pole 5 m	5	12	631 081
PSEN op cable axial M12 12-pole 10 m	10	12	631 082
PSEN op cable axial M12 12-pole 20 m	20	12	631 083
PSEN op cable axial M12 12-pole 30 m	30	12	631 084
PSEN op cable axial M12 12-pole 50 m	50	12	631 085

EC declaration of conformity

This product/these products meet the requirements of the directive 2006/42/EC for machinery of the European Parliament and of the Council. The complete EC Declaration of Conformity is available on the Internet at www.pilz.com/downloads. Representative: Norbert Fröhlich, Pilz GmbH & Co. KG, Felix-Wankel-Str. 2, 73760 Ostfildern, Germany